

Indexed by

Scopus®

DOAJ
DIRECTORY OF
OPEN ACCESS
JOURNALS

Crossref

ROAD
DIRECTORY OF OPEN ACCESS
RESEARCH RESOURCES

KoBSON

SCINDEKS
Srpski citatni indeksGoogle
Scholar

EXPLORATORY RESEARCH FOR DEVELOPING ADVANCED PUMPING AND COMPRESSOR EQUIPMENT ADAPTED TO ABNORMAL OPERATING CONDITIONS OF OIL AND GAS PRODUCTION

Yuri Appolonievich Sazonov

National University of Oil and
Gas «Gubkin University»,
Faculty of Mechanical
Engineering, Department of
Machinery and Equipment for
Oil and Gas Industry,
Moscow, Russia

Mikhail Albertovich Mokhov

National University of Oil and
Gas «Gubkin University»,
Faculty of Oil and Gas Field
Development, Department of
Oil Field Development and
Operation,
Moscow, Russia

**Vladimir Valentinovich
Mulenko**

National University of Oil and
Gas «Gubkin University»,
Faculty of Mechanical
Engineering, Department of
Machinery and Equipment for
Oil and Gas Industry,
Moscow, Russia

**Khoren Arturovich
Tumanyan**

National University of Oil and
Gas «Gubkin University»,
Institute of Petrophysics,
Moscow, Russia

**Mikhail Alexandrovich
Frankov**

National University of Oil and
Gas «Gubkin University»,
Institute of Petrophysics,
Moscow, Russia

**Victoria Vasilievna
Voronova**

National University of Oil and
Gas «Gubkin University»,
Institute of Petrophysics,
Moscow, Russia

Key words: oil and gas production, compressor, pump, turbine, research, computer modeling

doi:10.5937/jaes0-26356

Cite article:

Sazonov, A. Y., Mokhov, A. M., Mulenko, V. V., Tumanyan, A. K., Frankov, A. M., & Voronova, V. V. [2020]. Exploratory research for developing advanced pumping and compressor equipment adapted to abnormal operating conditions of oil and gas production. *Journal of Applied Engineering Science*, 18(4), 467 - 474.

Online access of full paper is available at: www.engineeringscience.rs/browse-issues

EXPLORATORY RESEARCH FOR DEVELOPING ADVANCED PUMPING AND COMPRESSOR EQUIPMENT ADAPTED TO ABNORMAL OPERATING CONDITIONS OF OIL AND GAS PRODUCTION

Yuri Appolonievich Sazonov¹, Mikhail Albertovich Mokhov^{2*}, Vladimir Valentinovich Mulenko¹, Khoren Arturovich Tumanyan³, Mikhail Alexandrovich Frankov³, Victoria Vasilievna Voronova³

¹National University of Oil and Gas «Gubkin University», Faculty of Mechanical Engineering, Department of Machinery and Equipment for Oil and Gas Industry, Moscow, Russia

²National University of Oil and Gas «Gubkin University», Faculty of Oil and Gas Field Development, Department of Oil Field Development and Operation, Moscow, Russia

³National University of Oil and Gas «Gubkin University», Institute of Petrophysics, Moscow, Russia

The observed instability of the oil and gas market makes it necessary to intensify the exploratory scientific research for the development of advanced and inexpensive pumping and compressor equipment intended for oil and gas production and treatment. The ongoing research work is being undertaken with a view to modernize well-known technical solutions and develop new scientific principles for gas compression with the use of labyrinth compressors. From the published materials, it became known that when designing labyrinth pumps, the screw auger on the pump rotor can be replaced with a set of vane wheels. This design approach should be transferred from the field of pumping technology to the field of compressor technology as well. At the initial stage of such research microlevel models of new turbocompressors have been developed to test their performance. Further, was made the transition from the low-cost physical experiments with micro-level models to a deeper study of the working process for the basic model of the compressor with the screw rotor. 3D-model development was carried out with the use of the SolidWorks 3D CAD-system. In order to undertake a calculation study, the FloEFD software package of computational fluid dynamics developed by Mentor Graphics Corporation has been used. The results of the research findings can be used for the development of energy-efficient technologies for the compression and pumping of various gases. The development of cheaper and more economical pump-compressor units will allow for the solution of urgent hydrocarbon exploration and production problems in abnormal operating conditions. Based on similar compressor units, there is a possibility to develop other sectors of science and technology as well.

Key words: oil and gas production, compressor, pump, turbine, research, computer modeling

INTRODUCTION

At the late stage of oil and gas field development, the need for additional pumping and compressor equipment is increasing due to reduced reservoir pressure. At the same time, the well-known compressor and turbine machines do not yet fully solve such urgent problems, because the operating conditions are complicated by the presence of liquid fractions and solid particles in the flow of the pumped medium [22, 23, 24, 25].

There are known technologies of oil and gas wells operation, where jet pumps and compressors are used for liquid and gas pumping at high content of mechanical impurities, as described in patents [1, 2] and papers [3-5]. Often an adjustable ejector is used. In this case, in one of the variants, the control is performed by changing the cross-section area in the flow channel at the nozzle, as described in patent [6]. In certain cases, the cyclic mode of the working medium flow through the nozzle of the jet device is considered. In this case, cyclical changes in the jet's operating parameters are provided by the rotating

disc, which is located inside the nozzle, as described in patents [7-9].

Labyrinth pumps operate very reliably at an increased concentration of mechanical impurities in the liquid flow, as is proven in our previous publications [10-12]. These publications describe new scientific principles for pumping multiphase media in the presence of a solid phase in the flow. It has been shown experimentally that the volume concentration of the solid phase in the flow can reach 50%. Perspectives for practical application of reversible pumps in pumping multiphase media have been shown. When studying the labyrinth pumps, it has been noted in the publications [10-12] that the screw auger can be replaced with a set of vane wheels. Upon that, the vane wheel can be of the enclosed or open type. The vane wheel as a part of the rotor can be made as a centrifugal wheel or as an axial wheel; other rotor designs are also possible. This area of pumping and compressor technology is still unstudied, referring to pumping and turbine technologies taking into account the reversibility of such hydraulic machines. It is noted in previous

*mikhail.mokhov@mail.ru

publications [10-12] that it is expedient to address further studies to solve optimization problems when using different rotor structures. The direction of research aimed at increasing the rotor speed is seen as very promising with the prospect for developing compact and powerful hydraulic machines, turbines and compressors.

Technical decisions where a flow direction is periodically changed in channels of the hydraulic system are known, as have been noted in paper [13]. However, operating peculiarities of reversible pumps have not been studied yet in sufficient detail, and the potential of such pumps for hydrocarbon production in abnormal operating conditions has not been fully revealed.

Special pumps and turbines have been developed for severe operational conditions, and each such hydraulic machine is equipped with a rotor made in the form of a mesh, as described in papers [14-15]. This rotor structure can withstand higher loads, and here we can refer to the experience of the development and application of grid-like wings described in monograph [16].

The active application of compressor and turbine technologies is currently being hampered by rather high prices for equipment, especially in a situation of falling oil and gas prices. In this regard, the development of new efficient and affordable pump, compressor and turbine units can be fully attributed to the urgent tasks.

CONCEPT HEADINGS

The purpose of the ongoing research work is to find and study new technical opportunities to develop promising

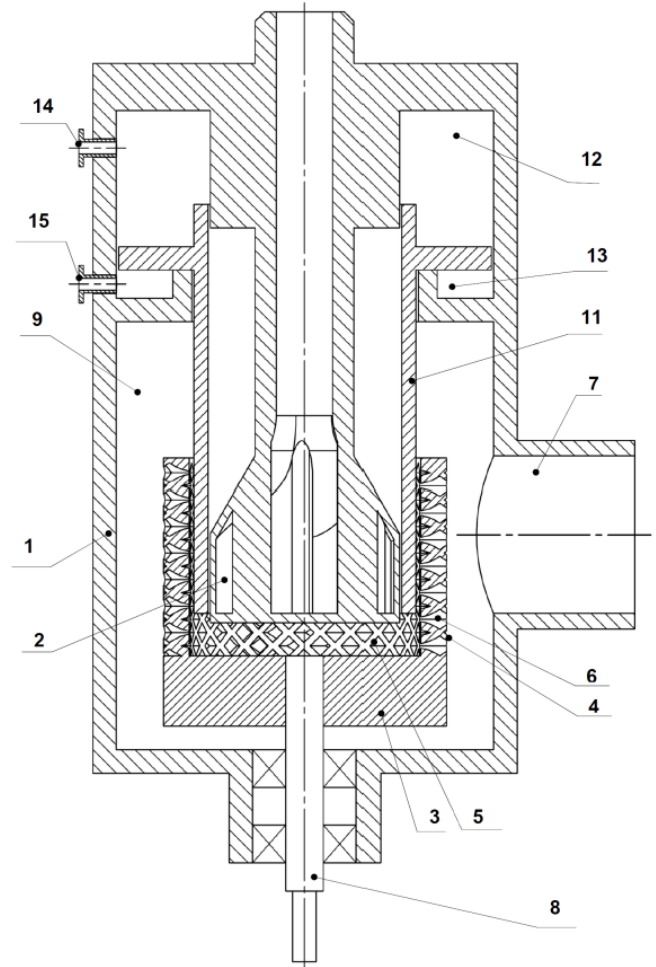

Figure 2: Scheme of the turbine with a closed nozzle

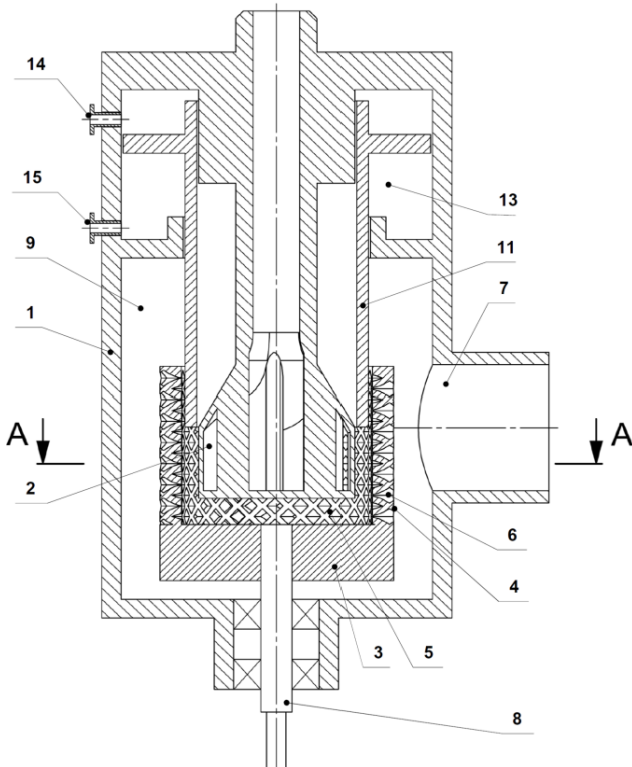

Figure 1: Scheme of the turbine with an open nozzle

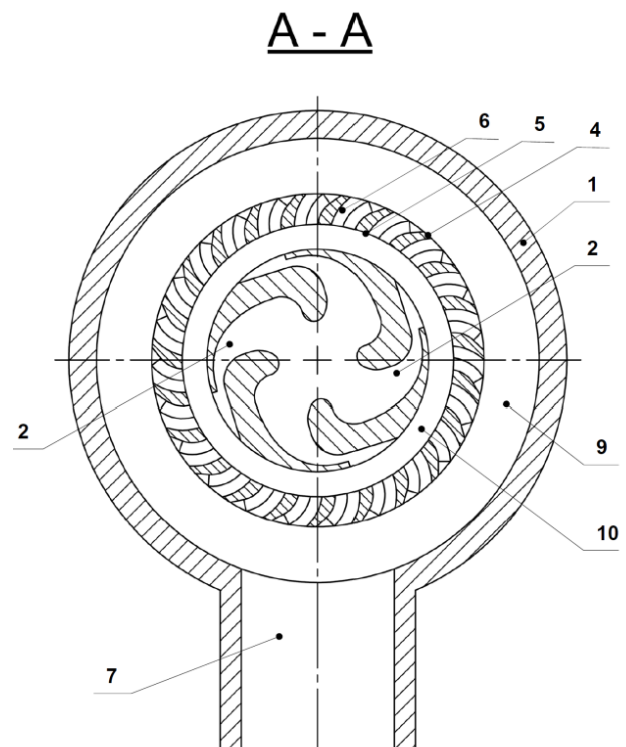

Figure 3: Cross section of the turbine

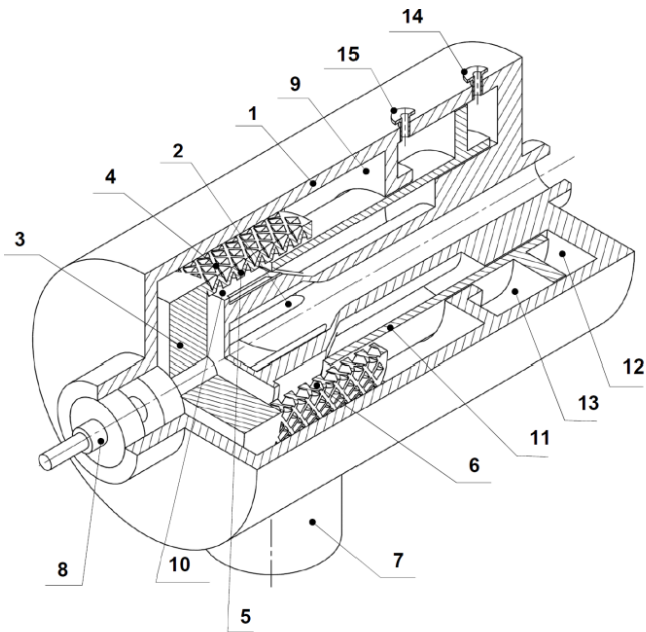

Figure 4: Scheme of the turbine with an open nozzle in isometric view

pumping and compressor equipment adapted to the abnormal operating conditions of oil and gas production. At this stage of work, certain issues are considered on expanding the field of practical use of labyrinth compressors and pumps, including through the increase of rotor speed.

RESULTS

Over the past years, in our opinion, there is a promising direction of work in the field of labyrinth pumps and compressors, related to the application of alternative rotor variants that can compete with the screw rotor, according to previous publications [10-12], especially at a higher rotation speed. For laboratory testing of microlevel models, a special turbine with a mesh rotor has been developed and manufactured. The design of the turbine is patented (the patent of the Russian Federation for the useful model No. 192513). Figures 1-4 schematically represent one of the developed versions of such turbine. In the future, it is planned to study the possibilities of using the mesh rotor as part of the compressor as well.

The presented turbine contains the stator 1 with input nozzles 2 and the rotor 3 with external projections 4 arranged in the said stator. The engine structure can have one, two or more nozzles. The rotor 3 is equipped with inner projections 5, at the same time, the rotor 3 is designed as a permeable volume honeycomb structure, consisting of the interconnected external projections 4 and inner projections 5. The projections 4 and 5 have solid walls. Between the inner 5 and external 4 projections, there are flow channels 6 in the rotor 3 with the hydraulic connection of the flow channels 6 in the rotor 3 with the input nozzles 2 in the stator 1. The stator 1 is equipped with the output channel 7. The input nozzles

2 and the output channel 7 can be located at different distances from the rotor rotational axis 8 of the rotor 3, taking into account the application conditions.

The stator 1 contains the vortex chamber 9 mounted coaxially with the rotor. The input nozzles 2 are located in the central part of the rotor 3, with the formation of the circulation ring channel 10 in the gap between the input nozzles 2 and the inner projections 5. The movable adjusting bushing 11 is located in the vortex chamber 9. The movable adjusting bushing 11 is designed with a possibility of its movement from the vortex chamber 9 into the circulation annular channel 10 for partial or complete overlapping of the input nozzles 2. The position of the movable adjusting bushing 11 can be changed using well-known technologies, such as hydraulic drive or electromagnetic drive. This example represents the hydraulically actuated version for moving the movable adjusting bushing 11. Hydraulic chambers 12 and 13 can be connected via connection pipes 14 and 15 to the hydraulic control system (the hydraulic control system is not shown in the figures). This paper also discusses options for controlling the turbine by using ejectors and other jet devices.

The turbine operates as follows. The stator 1 with the input nozzles 2 provides generating a flow (or several flows) of the working medium towards the rotor 3. Liquid, a gas-liquid mixture or gas (including steam or high-temperature combustion products of the fuel-air mixture) may be used as the working medium. The flow of the working medium affects the inner projections 5 of the rotor 3 and sets the rotor 3 in motion. Thus, the kinetic energy of the medium flow is converted into mechanical energy by the rotary motion of the rotor 3. For further energy transfer, the rotor 3 can be connected with external mechanisms which are not shown in the figures. The medium flow through the flow channels 6 also penetrates in the cavity of the rotor 3, which is designed as a permeable volume honeycomb (mesh) structure. The flow of the working medium in this part of the rotor 3 interacts with the hard walls of the inner 5 and external 4 projections, which promotes energy conversion. Both continuous and impulse supply of the working medium to the rotor 3 is possible. Due to the permeable volumetric honeycomb (mesh) structure of the rotor 3, energy conversion is provided at various properties of the working medium, including the use of gas-liquid mixtures with different density or viscosity. The working medium is removed from the stator 1 initially through the flow channels 6 in the rotor 3 and then through the output channel 7.

When moving the movable adjusting bushing 11 in the direction from the vortex chamber 9 to the circulation annular channel 10, it is possible to regulate the turbine through partial or complete overlapping the input nozzles 2.

The position of the movable adjusting bushing 11 can be changed. In order to close the input nozzles 2, the hydraulic chamber 12 is supplied with high-pressure fluid through the connection pipe 14. In this case, the

fluid is displaced from the hydraulic chamber 13 to the low-pressure line through the connection pipe 15. Due to the pressure drop in the hydraulic chambers 12 and 13, the movable adjusting bushing 11 moves and closes the input nozzles 2.

In order to open the input nozzles 2, the hydraulic chamber 13 is supplied with high-pressure fluid through the connection pipe 15. In this case, the liquid is displaced from the hydraulic chamber 12 to the low-pressure line through the connection pipe 14. Due to the pressure drop in the hydraulic chambers 12 and 13, the movable adjusting bushing 11 moves and opens the input nozzles 2. The intermediate position of the movable adjusting bushing 11 can be changed by changing the fluid volume in the hydraulic chambers 12 and 13 (as in the well-known hydraulically actuated control systems).

Performance of the presented turbine was tested during laboratory tests of the turbocompressor microlevel model. The rotor speed of the turbocompressor model was brought up to the level of 20000...30000 rpm in labora-

tory conditions using a special turbine. Compressed air was used for the turbine operation. Figure 5 represents a picture of the turbocompressor microlevel model. The housing of the turbocompressor microlevel model (red) can be seen in the photo on the right. The mesh rotor of the special turbine (white) can be seen in the photo on the left.

The microlevel model of the labyrinth compressor with the screw rotor was used during the tests.

It has been demonstrated during the laboratory tests that with increasing the rotor speed, the experimental compressor can provide a head up to 150 meters when the rotor diameter is equal to 30 mm and the rotor length is equal to 50 mm.

Modern computer technologies enable to leave behind a part of expensive physical experiments, gradually moving from physical experiments to virtual ones (numerical experiments). A series of virtual experiments have also been conducted during the presented research in order to quantify the technical characteristics of the labyrinth compressor. The developed three-dimensional model of the labyrinth compressor is illustrated in Figure 6. The screw auger as a component of the rotor can be made with a constant or variable pitch, with a cylinder or profiled bushing

Among the main parameters affecting the performance of the compressor are the following: geometric dimensions of the rotor vanes (screw auger), geometric dimensions of the vanes of the stator fixed screw channels, rotor speed, properties of the pumped gas.

The developed model includes the screw auger, which has a four-ways screw surface with the screw pitch of 348 mm. The stator also has a four-way screw surface with the screw pitch of 348 mm, but the direction of its screw surface is opposite to the direction of the screw auger surface. The outside diameter of the screw auger is equal to 365 mm, the rotor-bushing diameter is equal to 144 mm, and the screw length is equal to 300 mm. The radial clearance between the rotor and stator is 0.6 mm.

DISCUSSION

In the course of the research work, a digital model of the labyrinth compressor was developed. Preliminary optimization of the compressor flow section was performed already at the gas-dynamic modeling stage. Theoretical characteristics of the compressor have been determined.

3D-model development was carried out with the use of the SolidWorks 3D CAD-system. In order to undertake a calculation study, the FloEFD software package of computational fluid dynamics developed by Mentor Graphics Corporation has been used.

The problem statement of the virtual experiment is as follows: a single-phase turbulent flow of gas was simulated; air (the adiabatic value is $\gamma = 1.4$) is supplied to the working chamber of the compressor at the temperature

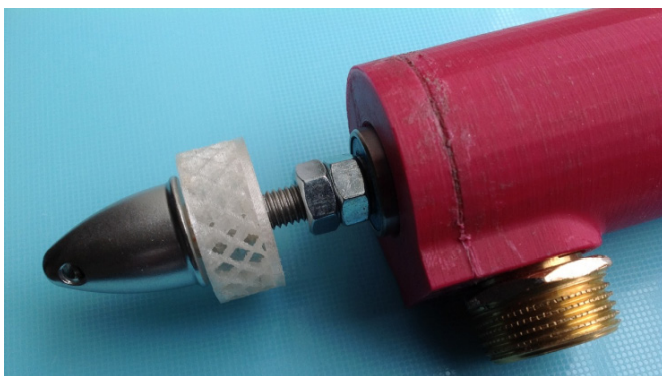

Figure 5: Photograph of the turbocompressor microlevel model

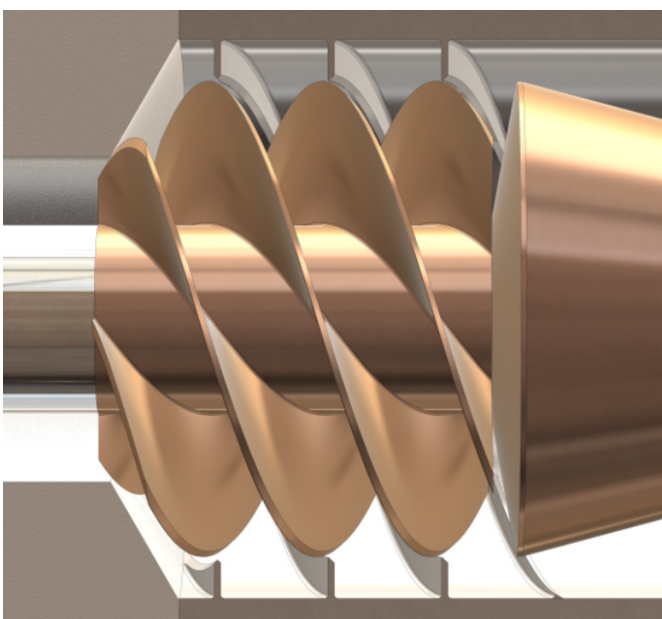

Figure 6: Three-dimensional model of the labyrinth compressor

of 293 K and static pressure of 0,3 MPa. Density and viscosity of the pumped gas are the library parameters and are recalculated by the program at each point of the computational domain depending on the gas temperature change.

The roughness of the surfaces in the computational domain was not taken into account. The rotor speed was set equal to 20,000 rpm. The research requires the determination of the pressure at the compressor discharge, the efficiency factor, and power consumption at various values of the mass gas flow rate (or at different compressor capacities). The mass gas flow rate varied in the range from 0 to 18 kilograms per second.

In the process of modeling, the complete system of Navier-Stokes averaged equations described by mathematical expressions of the mass conservation law, energy conservation law, and impulse law was solved. The system automatically carried out the transition between laminar and turbulent states in the whole computational domain. The turbulence parameters were set automatically by default. In order to calculate the turbulent parameters for the closure of the Navier-Stokes equation system, the k-ε model of the turbulent viscosity in Lam-Bremhorst modification was used. At the same time, the software package includes methods that make it possible to obtain a fairly accurate boundary layer solution for this and most other similar tasks, even on a rough mesh. Two variants of boundary layer calculation depending on flow parameters are realized in FloEFD software package: the "thick boundary layer" model (number of cells across the boundary layer is more than 10), the "thin boundary layer" model (number of cells across the boundary layer is less than 3), and the intermediate situation described in research [17]. In this case, two types of wall functions are used in the calculation.

The problem was solved with the following assumptions: the heat transfer in the flow is not taken into account, and all the walls which contact the pumped medium are thermally insulated (adiabatic).

A structured Cartesian grid was generated for the cal-

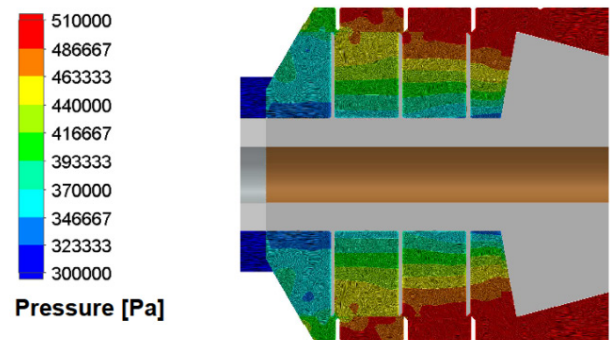

Figure 8: Change in gas output pressure in the compressor flow section

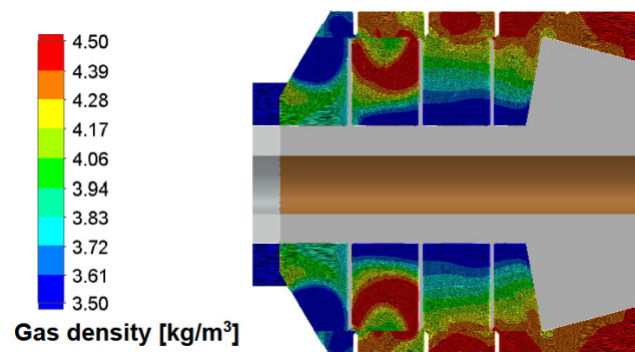

Figure 9: Change in gas density in the compressor flow section

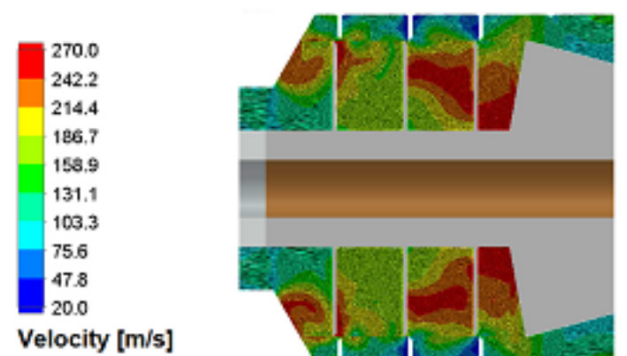

Figure 10: Change in gas velocity in the compressor flow section

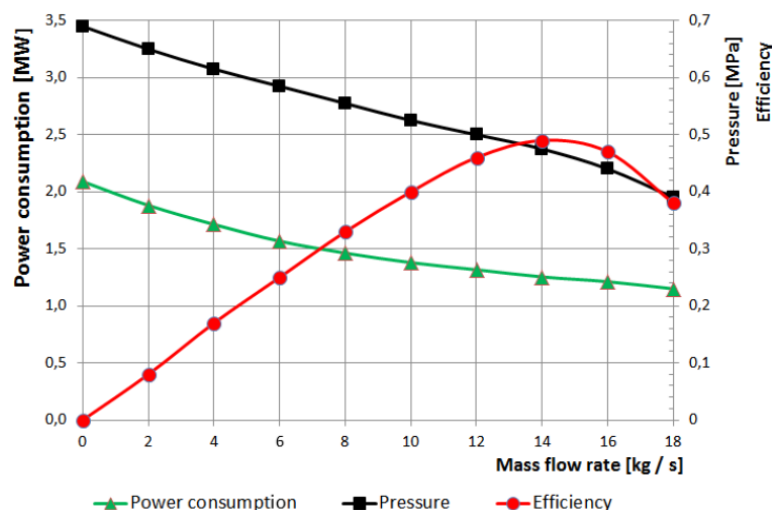

Figure 7: Theoretical characteristics of the experimental labyrinth compressor

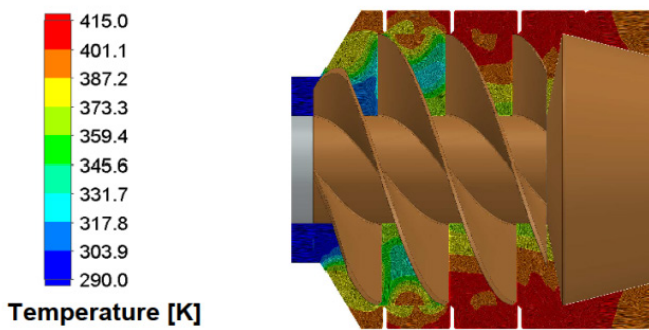

Figure 11: Change in gas temperature in the compressor flow section

ulation. FloEFD uses sliding mesh technology in order to simulate the rotation. Two additional local grids were given around fixed stator vanes and for the rotating area. A higher level of mesh crushing was specified for the local domains. The total number of grid elements was 1.5 million cells. The results of the grid independence study showed satisfactory results for that grid. The time required to calculate one point was about 10-15 hours. Calculations in the FloEFD software package were performed in a non-stationary setting, where the time step was chosen depending on the size of cells. The grid adaptation to the flux gradients in the computational domain was used in the process of counting.

Based on the results of virtual experiments, the theoretical characteristics of the experimental labyrinth compressor have been plotted. The results of the calculations are graphically presented in Figure 7. The behavior of parameters on the obtained theoretical characteristics has a certain similarity with the characteristics of labyrinth pumps, which have been demonstrated in works [18-21].

Figures 8-11 graphically represent the results of virtual experiments conducted in order to estimate changes in gas-dynamic parameters, including such parameters as pressure, density, gas velocity and temperature.

Based on the results of virtual experiments, it is possible to conclude about application possibilities of such compressor technique for the development of oil and gas fields in abnormal operating conditions. The characteristics of the considered compressor are suitable for solving many practical and relevant problems in oil and gas production and treatment. It is important to note a well-known fact that such labyrinth machine is capable of pumping gas-liquid mixtures. This opens up additional opportunities for organizing the cooling system of compressible gas directly in the working chamber of the compressor due to the supply of coolant into the screw channels of the stator. In this case, there is the prospect of developing a compact and affordable single-stage and multistage compressors. Because of the simplicity of the labyrinth compressor design, a reduction of investment and operating costs can be expected in the development of oil and gas fields

When studying the labyrinth pumps described in our previous papers [10-12], it has been noted that the screw auger can be replaced with a set of vane wheels. Upon that, the vane wheel as part of the rotor can be made as a centrifugal wheel or as an axial wheel; other rotor designs are also possible. The possibility of developing a labyrinth compressor in which the screw auger will be replaced with a set of vane wheels is of practical and scientific interest. Figure 12 represents a three-dimensional computer model of the new labyrinth compressor in which the screw auger is replaced with a set of vane wheels of axial type. The axial vane wheels are mounted between flat disks on the compressor rotor. The microlevel model of this compressor is developed with the application of additive technologies and tested in laboratory conditions as part of the turbocompressor. The rotor speed of the turbocompressor model was brought up to the level of 20000...30000 rpm in laboratory conditions using a special turbine. The compressed air was used to operate the net-shaped turbine. During the tests, similar results were obtained as in the tests of the microlevel model of the compressor with the screw rotor (the turbocompressor microlevel model with the screw rotor was presented in Figure 5).

Physical experiments with microlevel models of turbocompressors have demonstrated that the same techniques can be used for the development of science and technology in the field of compressor machines as for the development of new pumps, as is proven in our previous papers [10-12]. The screw auger in the labyrinth compressor can also be replaced with a set of vane wheels. Within the framework of the research development, it is planned to perform a series of virtual experiments for quantitative estimation of technical characteristics of the labyrinth compressor in which the screw is replaced with a set of vane wheels.

The scientific interest to the presented works is also supported by the fact that on the basis of similar technology, there is an opportunity to develop other sectors of

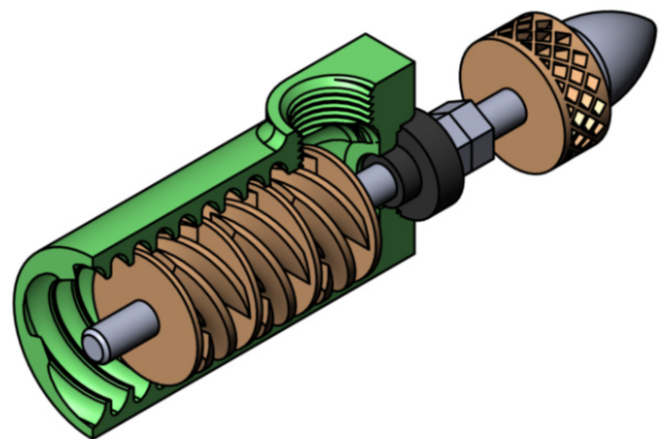

Figure 12: Three-dimensional computer model of the labyrinth compressor in which the screw auger is replaced with a set of vane wheels of axial type

science and technology, including gas turbine units for various purposes because it is known that today scientific and technical reserves for further improvement of available gas turbine units are already fully exhausted.

Under these circumstances, many specialists are now shifting to finding fundamentally new technical solutions, including technologies related to the isothermal compression, isothermal expansion of gases or impulse combustion of fuel-air mixtures at a constant volume. Some results of the works performed can also be used in the development of jet control systems for air-based or sea-based drones, including the solution of particular problems in the development of offshore oil and gas fields

CONCLUSIONS

In the framework of exploratory scientific research, the basic principles of designing the mesh rotor for turbomachinery equipment have been developed and patented. Such rotor can withstand higher loads due to its increased structural rigidity.

It is known from recently published materials that when designing labyrinth pumps, the screw on the pump rotor can be replaced with a set of vane wheels. This design approach should be transferred from the field of pumping technology to the field of compressor technology as well. Scientific research in this area is at an early stage. For deeper studying the working process, the basic model of the compressor with a screw rotor is considered. Based on the results of virtual experiments, the conclusion has been made about the application possibilities of such compressor technology in the development of oil and gas fields in abnormal conditions

The characteristics of the considered compressor are suitable for solving many practical and relevant problems in oil and gas production and treatment. Due to the simplicity of the labyrinth compressor design, a reduction of investment and operating costs can be expected in the development of oil and gas fields

Some results of the works performed can also be used in the development of jet control systems for air-based or sea-based drones, including the solution of particular problems in the development of offshore oil and gas fields

ACKNOWLEDGEMENTS

The work was performed with the financial support of the Ministry of Education and Science of the Russian Federation within the framework of the state contract in the sphere of scientific activities, topic number FSZE-2020-0006.

The Name of the project is "Investigation of gasdynamic and hydrodynamic processes in a pulsed flow regime through rotating and static channels with a mesh structure at subsonic and supersonic flow velocities"

REFERENCES

1. Falk, K.L. (2014). US Patent No. 8,863,827 B2. Jet pump for use with a multi-string tubing system and method of using the same for well clean out and testing.
2. Misselbrook, J.G. (2007). US Patent Application Publication No. 2007/0187111 A1. Apparatus and method for dewatering low pressure gradient gas wells.
3. Lea, J.F., Winkler, H.W. (2010). What's new in artificial lift. Part 1. Introducing developments in natural gas well dewatering. *World Oil*; March 2010, 51–59.
4. Brink, M. (2014). Jet pump technology for artificial lift in oil and gas production. *The Elomatic Magazine*, 1, 40–43.
5. Singh, M.K., Prasad, D., Singh, A.K., Jha, M., Tandon, R. (2013). SPE 166077-MS. Large Scale Jet Pump Performance Optimization in a Viscous Oil Field. SPE, Cairn India Ltd. Copyright 2013, Society of Petroleum Engineers. Technical Conference and Exhibition held in New Orleans, Louisiana, USA, 30 September – 2 October 2013.
6. Morishima, S. (2008). US Patent No. 7,438,535. Structure of ejector pump.
7. Castel, Y. (1996). US Patent No. 5,575,625. Multi-phase pump with sequential jets.
8. Castel, Y. (1997). US Patent No. 5,616,006. Pumping method and device with sequential jets.
9. Castel, Y. (1998). US Patent No. 5,716,196. Pumping method and device with sequential jets.
10. Mokhov, M.A., Sazonov, Yu.A., Frankov, M.A., Tumanyan, Kh.A., and Kruglov, S.V. (2019). Development and Research of a Multi-Phase Pump for Oil and Gas Production at a High Content of Mechanical Impurities in the Flow. *Journal of Computational and Theoretical Nanoscience*, 16(7), 2815–2821.
11. Mokhov, M.A., Sazonov, Yu.A., Frankov, M.A., Tumanyan, Kh.A., Kruglov, S.V., and Muradov, A.V. (2019). Development and Research of Multi-Phase Reversible Pump. *Journal of Computational and Theoretical Nanoscience*, 16(7), 3007–3012.
12. Mokhov, M.A., Sazonov, Yu.A., Mulyenko, V.V., Frankov, M.A., Tumanyan, Kh.A., Timoshenko, V.G., and Kruglov, S.V. (2019). Development of Pumping Equipment for Oil and Gas Production in Complicated Conditions. *Journal of Computational and Theoretical Nanoscience*, 16(11), 4573–4578.
13. Sazonov, Yu.A., Mokhov, M.A., Tumanyan, Kh.A., Frankov, M.A., and Markelov, S.I. (2019). Development of an automated compressor unit for gas compression at the periodic connection of an ejector. *Journal of Computational and Theoretical Nanoscience*, 16(12), 5378–5383.

14. Sazonov, Yu.A., Mokhov, M.A. (2016). Developing a Hydraulic Machine for Effective Use of Reservoir Energy in Offshore Production. *Indian Journal of Science and Technology*, 9(29), 1–6.
15. Sazonov, Yu.A., Mokhov, M.A., and Tumanyan, Kh.A. (2016). Developing Special Turbine for Rational Utilization of Reservoir Energy of Hydrocarbon Deposits. *Indian Journal of Science and Technology*, 9(42), 1–7.
16. Bilotserkovskiy, S.M., Odnovol, L.A., Safin, Yu.Z., Tyulenev, A.I., Frolov, V.P., Shitov, V.A. (1985). *Grid-like wings*. Moscow: Mechanical Engineering.
17. Sobachkin, A., Dumnov, G. (2013). Numerical Basis of CAD-Embedded CFD. *NAFEMS World Congress*.
18. Zotov, B.N. (2014). Calculation of screw auger characteristics of constant and variable pitch for centrifugal pumps. Moscow: Mechanical Engineering.
19. Zotov, B.N. (2006). Investigation of the inverse currents in the pumps and the methodology of the axial-vortex-flow stage characteristics calculation. *Chemical and Petroleum Engineering*, 5, 30–32.
20. Zotov, B.N. (2007). Calculation methodology of the axial-vortex-flow pump characteristics. *Heavy engineering*, 3, 5–6.
21. Ankudinov, A.A., Kirillov, A.A. (2009). *Computer-assisted design of the pump axial-vortex-flow stage: a training manual*. Moscow: Publishing House of the N.E. Bauman Moscow State Technical University.
22. Zheng, S., Yang, L. (2017). Numerical Experiments of Dynamic Response of Buried Gas Pipeline under the Action of Seismic Waves Induced by Tunnel Blasting. *Journal of Southwest Jiaotong University*, 52(2). <http://jsju.org/index.php/journal/article/view/29>
23. Liu, Z., Li, L., Han, Z., Pan, J., Ding, Y. (2016). Current Following Segmented PID Control of Air Supply System in Heavy-Duty PEMFC System. *Journal of Southwest Jiaotong University*, 51(3). <http://jsju.org/index.php/journal/article/view/120>
24. Bukhtoyarov, V.V., Tynchenko, V.S., Petrovskiy, E.A., Buryukin, F.A. (2019). Comparative Analysis of Methods for Simulating the Well Operation with Electric Submersible Pump Installations. *Periódico Tchê Química*, 16(32), 621–632.
25. Da Silva, F.N., Da Cunha, J.D., Barbosa, A.F.F., Da Silva, D.R. (2014). Evolution of the Column Fouling Production in Wells Producing Oil and Gas: Case Study. *Periódico Tchê Química*, 11(22), 64–70.

Paper submitted: 30.04.2020.

Paper accepted: 13.05.2020.

*This is an open access article distributed under the
CC BY 4.0 terms and conditions.*