

Indexed by

Scopus®

METHOD FOR DETERMINING WORKING REGIMES WITH REASONABLENESS OF EQUIPMENT CASING PIPES BY ROTARY PRESS – INDOAJ
DIRECTORY OF
OPEN ACCESS
JOURNALS

Crossref

Minh Pham Van*Faculty of Mechanical
Engineering, National
University of Civil Engineering,
Hanoi, Vietnam***Dung Pham Quang***Faculty of Mechanical
Engineering, National
University of Civil Engineering,
Hanoi, Vietnam*ROAD
DIRECTORY OF OPEN ACCESS
RESEARCH RESOURCES

KoBSON

SCINDEKS
Srpski citatni indeksGoogle
Scholar

Key words: *equipment casing, rotary press – in method, base machines, reasonable working regimes*

doi:10.5937/jaes0-33110

Cite article:

Pham Van M., Pham Quang D. (2022) METHOD FOR DETERMINING WORKING REGIMES WITH REASONABLENESS OF EQUIPMENT CASING PIPES BY ROTARY PRESS – IN, *Journal of Applied Engineering Science*, 20(2), 447 - 454, DOI:10.5937/ jaes0-33110

Online access of full paper is available at: www.engineeringscience.rs/browse-issues

METHOD FOR DETERMINING WORKING REGIMES WITH REASONABLENESS OF EQUIPMENT CASING PIPES BY ROTARY PRESS – IN

Minh Pham Van*, Dung Pham Quang

Faculty of Mechanical Engineering, National University of Civil Engineering, Hanoi, Vietnam

According to the collected data of soil mass in the cone penetration test, the research paper defines a drag on the steel casing pipe used for constructing bored pile by the rotary press – in method. Hence, this paper proposes a way of defining the working regime with the reasonableness of equipment casing by this technique, which will be regarded as a necessary step to design the installation of the equipment on the available base machine in Vietnam with the intention of not only maximizing the capacity of transmission but also improving the machine’s productivity as well. It makes a contribution to reduce the investment’s costs and increase the effective exploitation of this equipment in Vietnam.

Key words: equipment casing, rotary press – in method, base machines, reasonable working regimes

INTRODUCTION

The construction of bored pipe by the method used the casing for the whole drill hole is applied to the complicated geology condition, allowing to ensure the quality and trust of bored pile. Thus, this method has been widely applied in over the world and this is also the first time to apply in Viet Nam for executing big projects with the complicated geology condition (i.e., My Thuan Bridge, Can Tho Bridge...). In addition, the technology and executed equipment has been recently developed and improved by many companies as shown in [1-3]. The set of equipment casing by a rotary press – in method (RPM) for constructing the bored pile pointed out in Figure 1. It comprises a base machine 1 working with the equipment 4 and connecting to the structure 5 [1-3]. The working equipment consists of two main parts which are pressing mechanism and rotary mechanism used for penetrating the casing pipe 2 into the ground according to the spiral orbit. The function of the base machine is not only to provide the transmission source for working equipment but also prevent working equipment from a rotating by connecting to the structure 5 as well. Nowadays, this kind of the equipment has a great demand to use for constructing the bored piles in construction on the ground with complicated geological conditions (it should be noted

that this equipment is able to ensure the quality of the constructed bored pile). Hence, the studies on designing, manufacturing and exploiting for this equipment are effectively necessary.

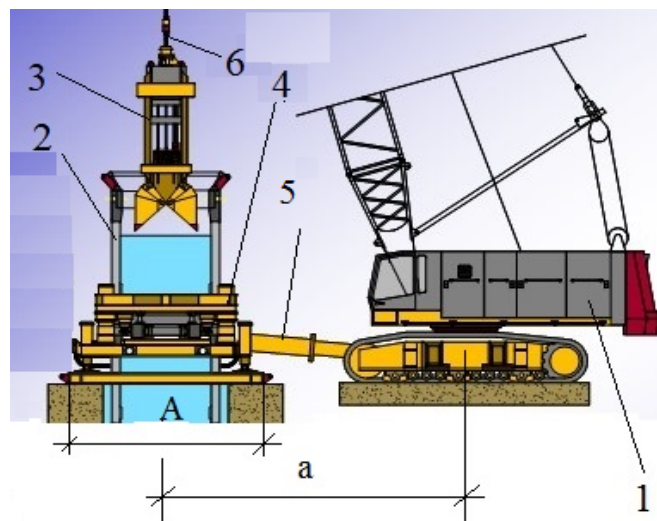

Figure 1: Modeling of the set of equipments casing by rotary press – in method [1-3] 1. Base machine; 2. Casing pipe; 3. Bucket; 4. Working equipment; 5. Structure using for connecting base machine with working equipment;

Table 1: The specification of rotary – press in equipment [1-3]

Name (brand)	LIEBHERR- LEFFER			SOILMEC		
	RDM-1500	RDM-2000	RDM-3000	RDM-1500	RDM-2000	RDM-3000
Diameter, [mm]	800 ÷ 1500	1200 ÷ 2000	2000 ÷ 3000	800 ÷ 1500	1200 ÷ 2000	2000 ÷ 3000
Torque Mmax, [KN.m]	2300	2900	7400	2700	4081	7544
Speed n, [rpm]	0 ÷ 1.1	0 ÷ 1	0 ÷ 1.75	0 ÷ 1.1	0 ÷ 1	0 ÷ 0.09
Pressing force Nmax, [KN]	1890	2400	4560	1890	2400	4560
Kind of base machine	HS 833 HD	HS 855 HD	HS 885 HD	R625	R825	R930
Weight, [KN]	320	420	800	440	650	1150

By comparing specification of the type of equipment produced by famous brands presented in Table 1 [1-3], it is clear that the available bored pile drilling rig can be used as the base machine in the set of equipment in order to reduce the cost and improve the exploited efficiency. The process of penetrating casing steel pipe into the ground by working equipment shown in Figure 2 is cyclical (lowered depth is equivalent to the stroke length of cylinder 8). At the starting point of cycle, the cylinder 8 is in the fully extended status, and the controlling cylinder 6 through the frame 5 is lower than wedge 3 for connecting to the inner ring of rotary headrest device installed on the main frame 2 with casing pipe 4. Simultaneously, the pulling cylinder 8 with the opening of rotary mechanism 9 is used for the lower casing pipe 4 via the main frame 2, rotary headrest device 7 and wedge 3. When the cylinder 8 reaches to the maximum point of stroke length, the cylinder 6 is able to separate the wedge 3 from the casing pipe 4. It is also extended to start a new cycle.

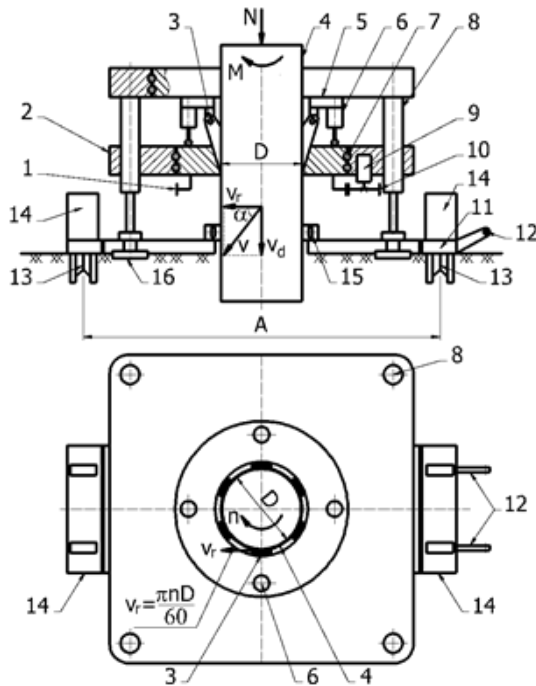

Figure 2: The diagram of equipment casing by rotary Press – in method

1. Gear ring of rotary headrest device; 2. Main frame; 3. Wedge; 4. Casing pipe; 5. Wedge frame;
6. Cylinder controlling wedge; 7. Rotary headrest device; 8. Pressing cylinder and guide frame;
9. Rotating casing pipe mechanism; 10. Proactive gear;
11. Platform of working equipment; 12. Parts junction with base machine; 13. Restraint; 14. Counterweight

For the purpose of ensuring the stability of working machine during working process, the weight of working equipment with the counterweight 14 keeps working machine from “uplifting” the under pressing force N . Together with the restraint 13, it is not only the friction force between working equipment and the ground but also the

friction force between the base machine and the ground (through the frame 5 – as shown in Figure 1) that prevent working equipment from being rotated by a shaft torque (M).

DETERMINATION OF RESISTANCES ON CASING PIPE PENETRATED BY THE RPM ACCORDING TO DATA FROM CONE PENETRATION TEST (CPT)

The equipment casing by the RPM and a steel casing pipe are bearred by the combination of a rotational jacking force (torque) and a vertical jacking force. The soil's resistance on a pile is combined with forces that have no any relevance to the interaction of the pile soil, including the pile's weight and the chucking part's weight of the equipment casing pipe. By omitting unnecessary forces, these components are synthesized into the vertical resistance N and the rotational torque in the horizontal plane M . The model for determining the drag acting on the casing pipe is shown in Figure 3, where parameters (N and M) consist of the resistive components at the tip of the base component (base force (N_b) and base torque (M_b)) and the resistance on a shaft component (vertical shaft force N_s , shaft torque M_s) is expressed in the below equations, i.e.

$$N = N_b + N_s, \quad (1)$$

$$M = M_b + M_s, \quad (2)$$

where the term N_b is calculated by the Lehane, X_u and Kempfert methods [4-6], including the influence of the soil mass inside the casing pipe and change state of soil mass in the bottom casing pipe when being lowered.

$$N_b = q_b \cdot \frac{\pi D^2}{4}, \quad (3)$$

where q_b includes the effect of resistance of the soil mass in the bottom casing pipe [5, 6] being the intensity of closed-ended casing pile with the outer diameter D (large diameter pipe). Thus, it is defined as:

$$q_b = (0,15 + 0,45A_r)q_c, \quad (4)$$

where $A_r = 1-(d/D)^2$ is given by Figure 3(b), q_c is defined according to the CPT tip stress at piling depth (KN/m^2) [7, 8], and the parameters of d and D are respectively the internal and external diameters of the casing pipe respectively (the unit is in m). The vertical resistance generated by sliding resistance and distributed on the shaft casing pipe is determined by the below equation:

$$N_s = N_{sp} + N_{is}, \quad (5)$$

where N_{is} is the vertical resistance of the casing pipe and N_{sp} the vertical resistance force of the outside casing pipe. When a factor of the surface area of the casing

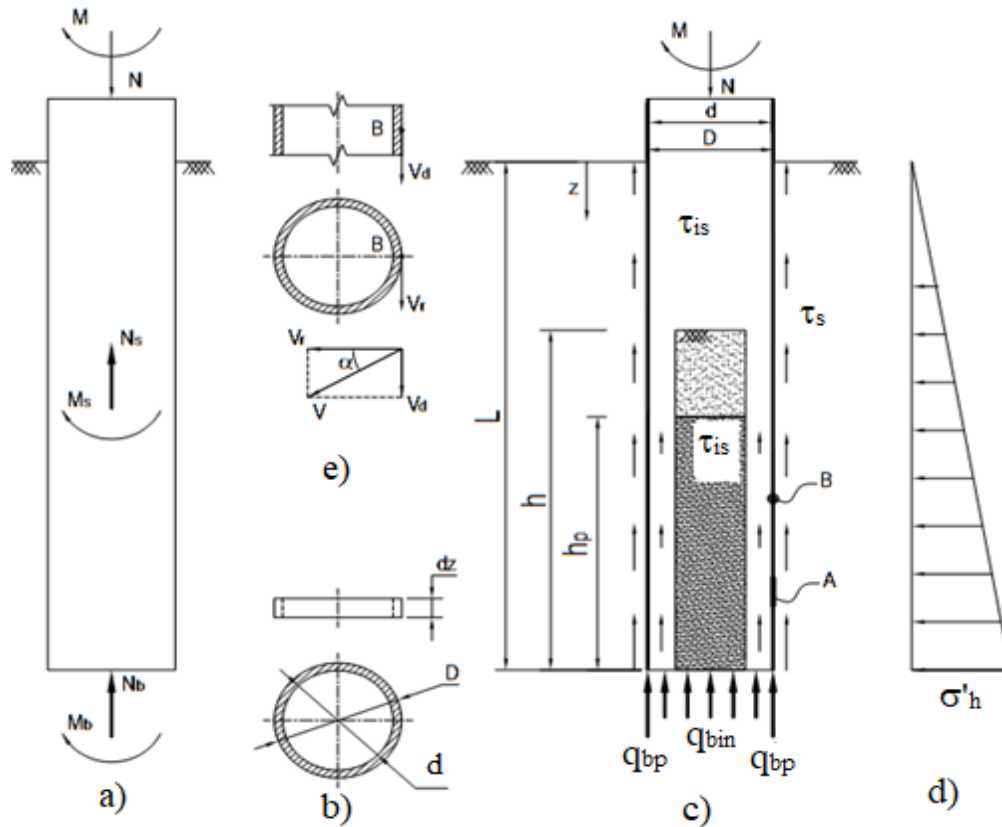

Figure 3: Model for determining the resistance force acting on the steel wall pipe a) force balance diagram, b) the pipe area element in the axial direction (z), c) diagram of the stress components of the soil acting on the wall pipe during lowering, d) earth pressure acting on the wall of the pipe, e) velocity on the pipe surface.

pipe is calculated by $dA = \pi D dz$ (Figure 3, b), the sliding resistance distributed on the casing pipe surface is $\tau_s = \sigma'_h \tan \delta_s + c_c$ [9]. For that, one has: $dN_{sp} = \tau_s dA = \tau_s \pi D dz = \pi D (\sigma'_h \tan \delta_s + c_c) dz$, (6) where σ'_h is the horizontal effective stress (KN/m²) (Figure 3, d), δ_s is the friction angle between soil and the steel casing pipe (degree) and c_c is the force created by cohesion of soil and steel casing pipe taken from the CPT (KN/m²) [7, 8]. It should be noted that if v_r is the long velocity in the horizontal plane, v is the slide velocity and v_d is the vertical velocity of any point B on the surface casing pipe (Figure 2 and Figure 3 (d)). The term α is the angle between the slide velocity and long the horizontal velocity. Hence, one gets:

$$\tan \alpha = \frac{v_d}{v_r}; n = \frac{60v_d}{\tan \alpha D \pi}; \alpha = 0^\circ \div 90^\circ, \quad (7)$$

Then unit friction slide is illustrated in Figure 4 (a) and the vertical force generated by the resistance on the surface shaft casing pipe is computed by the below equation:

$$\begin{aligned} N_{sp} &= \frac{\tan \alpha}{\sqrt{1 + \tan^2 \alpha}} \int_0^z dN_{sp} \\ &= \frac{\tan \alpha}{\sqrt{1 + \tan^2 \alpha}} \pi D \int_0^z (\sigma'_h \tan \delta_s + c_c) dz. \end{aligned} \quad (8)$$

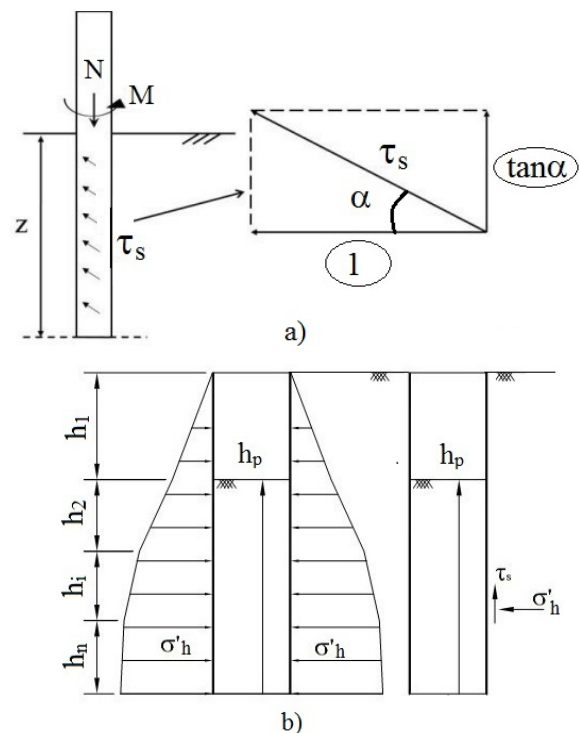

Figure 4: Lower wall pipe through n layers of soil a) Unit friction slide, b) Effective stress across multiple soil layers

The casing pipe is penetrated through n layers of soil, if σ'_{hi} is taken as the mean effective stress value of the i_{th} soil layer (KN/m^2), δ_{si} is the friction angle of the i_{th} soil layer and the steel casing pipe (degree), c_{ci} is the soil cohesion of i_{th} soil layer and steel casing pipe which is taken from the CPT (KN/m^2) [7, 8]. The equation (8) is then written as:

$$N_{sp} = \frac{\tan \alpha}{\sqrt{1 + \tan^2 \alpha}} \pi D \left(\sum_{i=1}^n h_i (\sigma'_{hi} \tan \delta_{si} + c_{ci}) \right), \quad (9)$$

where h_i is the i_{th} soil layer thickness. In the same way, the vertical force friction of the soil mass in the bottom casing pipe N_{is} is defined by the below equation:

$$N_{is} = \frac{\tan \alpha}{\sqrt{1 + \tan^2 \alpha}} \pi d h_p (\sigma'_{hp} \tan \delta_{sp} + c_p), \quad (10)$$

where σ'_{hp} is the horizontal effective stress of the load of the soil mass in the bottom casing pipe (KN/m^2), δ_{sp} is the friction angle of the soil mass in the bottom casing pipe and the steel (degree), c_p is soil cohesion of the soil mass in the bottom casing pipe and steel taken from the CPT (KN/m^2) and h_p is the effective height of the soil column at the bottom casing pipe which is empirically taken $0.8h$ (m) [4-6]. The torque in the horizontal plane at the tip of the casing pipe is considering as an elemental area on the cross-sectional area of the casing pipe $dA = 2\pi r dr$, where r ($d/2 \div D/2$) is the distance between the center of the tube and the inside and outside of the casing pipe surface (Figure 3, b). The elemental friction sliding force between the soil and the tip of the casing pipe is calculated by the below equation:

$$dF_b = q_b \tan \delta_{sp} dA = 2\pi r q_b \tan \delta_{sp} dr \quad (11)$$

The friction moment of an elemental area on the center of the section is expressed as:

$$dM_b = 2\pi r q_b \tan \delta_{sp} r dr \quad (12)$$

$$N = q_b \cdot \frac{\pi D^2}{4} + \frac{\pi D \tan \alpha}{\sqrt{1 + \tan^2 \alpha}} \cdot \left(\sum_{i=1}^n h_i (\sigma'_{hi} \tan \delta_{si} + c_{ci}) \right) + \frac{\tan \alpha}{\sqrt{1 + \tan^2 \alpha}} \cdot \pi d h_p (\sigma'_{hp} \tan \delta_{sp} + c_p); kN \quad (17)$$

$$M = \frac{\pi q_b \tan \delta_{sp}}{12} (D^3 - d^3) + \frac{\pi D^2 \cdot (\sum_{i=1}^n h_i (\sigma'_{hi} \tan \delta_{si} + c_{ci}))}{2\sqrt{1 + \tan^2 \alpha}} + \frac{\pi d^2 h_p \cdot (\sigma'_{hp} \tan \delta_{sp} + c_p)}{2\sqrt{1 + \tan^2 \alpha}}; kNm \quad (18)$$

Therefore, the parameters of the geological condition and equipment of casing pipe, N , M , v_d and n used for the design of equipment casing by rotary press – in method are able to be calculated by the equations (7), (17) and (18). However, in the equations (7), (17), (18), the value of the functions N , M , v_d and n depends on the term of α . On the other hand, each value of α_j leads to a different set of parameters (N_j , M_j , v_{dj} , n_j), which is specific for working regime of working machines.

METHOD OFF DEFINING REASONABLE WORKING REGIMES

The aim of problems is to define the reasonable working regimes of the equipment casing by the RPM, which

From the equation (12), the moment resistance of the sliding friction force applied to the tip of casing pipe is defined as:

$$M_b = \int_{\frac{d}{2}}^{\frac{D}{2}} \{ (q_b \tan \delta_{sp} 2\pi r dr) r \} = \frac{\pi q_b \tan \delta_{sp}}{12} \cdot (D^3 - d^3), \quad (13)$$

where q_b and δ_{sp} are respectively given from the equations (4) and (10). The torque in the horizontal plane on the shaft casing pipe is calculated by the following equation:

$$M_s = M_{sp} + M_{is}, \quad (14)$$

In the similar way to the transformation of the equation (9), the torque of the outer surface M_{sp} and inner surface M_{is} of the casing pipe is determined by the following equations:

$$M_{sp} = \frac{1}{\sqrt{1 + \tan^2 \alpha}} \pi \frac{D^2}{2} \int_0^z \tau_s dz = \frac{\pi}{\sqrt{1 + \tan^2 \alpha}} \frac{D^2}{2} \left(\sum_{i=1}^n h_i (\sigma'_{hi} \tan \delta_{si} + c_{ci}) \right), \quad (15)$$

$$M_{is} = \frac{1}{\sqrt{1 + \tan^2 \alpha}} \pi \frac{d^2}{2} \int_0^z \tau_{is} dz = \frac{1}{\sqrt{1 + \tan^2 \alpha}} \frac{\pi d^2 h_p}{2} (\sigma'_{hp} \tan \delta_{sp} + c_p), \quad (16)$$

where h_i , σ'_{hi} , δ_{si} , c_{ci} , n , h_p , δ_{sp} , σ'_{hp} , c_p are respectively given from the equations (9) and (10). By combining the equations (9) and (10) with the equation (1), the equations (15) and (16) with the equation (2), one has:

is suitable for the base machine in Vietnam. Based on the input parameters known in advance (geological conditions of soil mass; casing steel pipe; selected base machines), the value of α_{hl} corresponding to the reasonable working regime (N , M , v_d , n_{hl}) of the working equipments is defined to bring into play a maximum power of machines and powers, and to obtain the highest point of the productivity of the machine (v_d^{max}). This means that it will be satisfied the requirements of the process of lowering casing steel pipe given in equations (7), (17), (18) and ensuring the stability of working equipment with small counterweight.

The law of variation and the relation of specific parameters for working regimes of working equipments

The law of variation of pressing force (N) and rotary torque (M) regarding to the papermeter (α) is defined by the equations (17) and (18) (see Fig. 5). On the other hand, the pressing speed (v_d) and rotary speed (n) depend on each other in the equation (7). Therefore, each value of α defines the corresponding values of N and M according to the Figure 5. However, the n and v_d are proportional to each other by α in the equation (7) to ensure the process of lowering casing pipe into the ground.

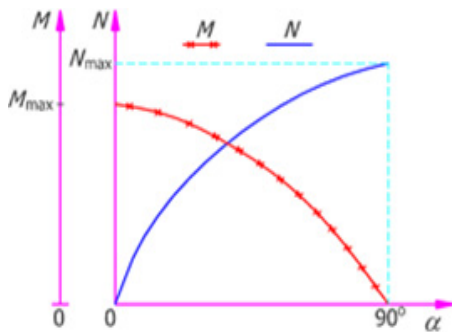

Figure 5: The law variation of M and N flowing to α

The power (P_e) of the base machine used for transmitting mechanism of pressing casing pipe is defined as:

$$P_e = \frac{Nv_d}{\eta_e}; k W, \tag{19}$$

$$\begin{cases} N = q_b \cdot \frac{\pi D^2}{4} + \frac{\tan \alpha}{\sqrt{1 + \tan^2 \alpha}} \cdot \pi D \left(\sum_{i=1}^n h_i (\sigma'_{hi} \tan \delta_{si} + c_{ci}) \right) + \frac{\tan \alpha}{\sqrt{1 + \tan^2 \alpha}} \cdot \pi d h_p (\sigma'_{hp} \tan \delta_{sp} + c_p) \\ M = \frac{\pi q_b \tan \delta_{sp}}{12} \cdot (D^3 - d^3) + \frac{\pi D^2 \cdot (\sum_{i=1}^n h_i (\sigma'_{hi} \tan \delta_{si} + c_{ci}))}{2\sqrt{1 + \tan^2 \alpha}} + \frac{\pi d^2 h_p \cdot (\sigma'_{hp} \tan \delta_{sp} + c_p)}{2\sqrt{1 + \tan^2 \alpha}} \\ n = \frac{60v_d}{\tan \alpha D \pi} \\ P_e = \frac{Nv_d}{\eta_e} \\ P_x = \frac{\pi M n}{30\eta_x} \end{cases} \tag{21}$$

Steps of solving problems for determining reasonable working regimes of working equipments

Required parameters

- Geological conditions of soil mass necessary for lowering steel casing pipe are the inner geological section (n_i, h_i); physical-mechanical properties of soil layers ($q_c, q_b, \sigma'_{hi}, \sigma'_{hp}, \delta_{si}, \delta_{sp}, c_{ci}, c_p$) according to the CPT and CPTu [7, 8];
- The requirements with casing pipe needs to be lowered (D, d, L, h_p);

and the mechanism of rotating casing pipe (P_x) is determined by the following equation:

$$P_x = \frac{\pi M n}{30\eta_x}; k W, \tag{20}$$

where η_e and η_x is the transmission efficiency of the pressing and rotating mechanism, respectively. Figure 5 shows that the smaller the value of α is, the smaller the value of N is and the greater the value of M is. If the value of α is small, the research question will be solved easily, because when the value of N is small, the value v_d is then great and the machine efficiency is high. On the other hand, if the value of N is small, the counterweight is small as well. However, if the value of N is small, the value of rotary torque M is great. In addition, with a great value of v_d , which is given by the equation (3), the value of n is great. This leads to a high capacity of rotating casing, resulting in source capacity of base machine not being adapted. Therefore, in order to determine the reasonable working regime of working equipment, it is vital to calculate the values of (N, M, v_d , n) with ($\alpha = 50^\circ \div 90^\circ$) and define v_d^{max} and N min, which meets with requirement of not only the process of lowering casing pipe but also keeping transmission source of base machine enough to drive the working machine in this working regime. The general mathematical model is stated as in the equation (21).

- Base machine: Refer to specification of this machine produced by the brands named in the Table 1, it is available for bored pile to drill a suitable rig for the requirements of soil mass and the casing pipe mentioned above (transmission diagram, P_e, P_x , Weight G_{cs} , the size of machine).

Sequence of defining specific parameters for working regimes of working equipments (N_p, M_p, v_{dp}, n) corresponding to a value of α_j

- Step 1: with the given value of α_j , the value of N_j, M_j is defined via the equations (17) and (18);

- Step 2: With the given value N_j , M_j , the value of pressing speed v_{dj1} is defined via the equation (19) (maximizing the capacity of pressing mechanism). With the value of v_{dj1} , the rotary speed n_{j1} is determined via the equation (7);
- Step 3: By using the equation (20), the value of rotary speed n_{j2} is defined via the values of M_j and P_x (maximizing the capacity of rotating structure), and also by using the value of n_{j2} , the value of v_{dj2} is defined via the equation (7);
- Step 4: If the value of $n_{j1} \leq$ the value of n_{j2} , the capacity P_x is enough to rotate casing pipe. For the value of α_j , the specific parameters of working regime are (N_j , M_j , $v_{dj} = v_{dj2}$, $n_j = n_{j2}$);
- Step 5: If the value of $n_{j1} >$ the value of n_{j2} , the capacity P_x is not enough to rotate casing pipe. For the value of α_j , the specific parameters of working regime are (N_j , M_j , $v_{dj} = v_{dj2}$, $n_j = n_{j2}$).

Determining the reasonable working regime of working equipment

The reasonable working regime of working equipments is the one which is corresponding to a reasonable α angle with a maximum speed of pressing casing pipe ($v_d = v_d^{max}$). Hence, it is vital to investigate and define specific parameters (N_j , M_j , v_{dj} , n_j) as process stated in Section 3.2.2, with α_j in its definite domain from $5^\circ \div 90^\circ$ ($\alpha_1 = 5^\circ$, $\alpha_j = \alpha_{j-1} + \Delta$, $\alpha_m = 90^\circ$, the number of iterations $m = (90 - 5)/\Delta$). In order to determine the reasonable working regime with $v_d^{max} = \max(v_{dj}$, with $j = 1 \div m$), the process of iterations can be programmed on a computer with m times of iterations to find out v_d^{max} with the diagram given in Figure 5. After defining the working regime of working equipments, it is able to use specific parameters M , N , v_d , n as inputs to design the working equipment, that is:

- Calculating the mechanism of the working equipment: the structure of pressing casing pipe, the structure of rotating casing pipe, the structure of controlling wedge;
- Calculating the steel structure, the platform system of working equipment and determining its own weight of the working equipment - G_o ;
- Calculating counterweight G_d which ensures stable condition to prevent the working equipment form "up-lifting" under the pressure of compression force N :

$$G_d = k_1 N - G_o, \tag{22}$$

where $k_1 = 1.1 \div 1.2$ is the safety factor longitudinal stability.

- Calculating anti-rotation area F (m^2) which ensures stable anti-rotation condition of the working equipment under the effect of rotary torque M [10, 11]:

$$2pFA + \frac{f(G_0 + G_d)A}{2} + fG_{cs}a = k_2 M \rightarrow F = \frac{k_2 M - f \cdot [0.5A(G_0 + G_d) + aG_{cs}]}{2pA}, \tag{23}$$

where $k_2 = 1.1 \div 1.2$ is the safety coefficient horizontal stability, f is the friction coefficient between the platform of equipment and the chain of the base machine to the ground, parameters (A and a) is given in Figure 1 and 2, G_{cs} is the weight of base machine (kN) and p is allowable stress of the ground (kN/m^2).

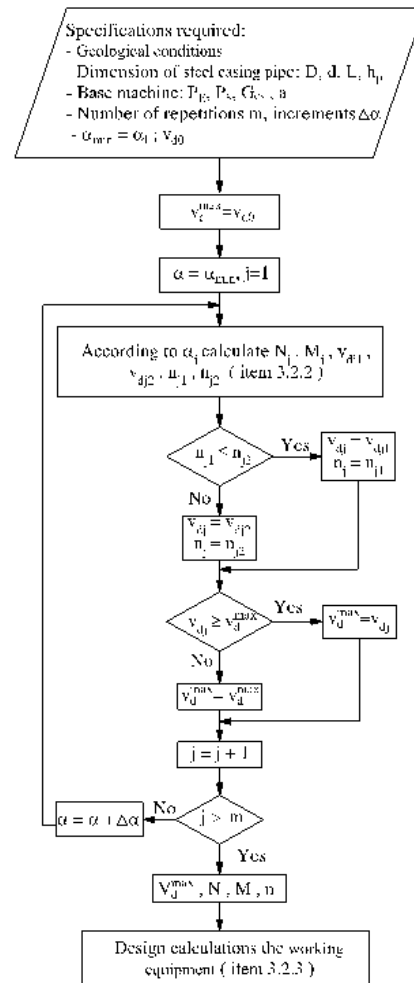

Figure 6: Block diagram of the method of defining the working regime with reasonableness of working equipment

APPLICATION TEST

Required parameters:

- The geological section of the soil mass of P6 pillar of My Thuan bridge in Viet Nam is illustrated in Figure 7 and their physical-mechanical properties are given in Table 2.

Table 2: The physio-mechanical properties of the soil mass

Parameter	h[m]	q _c [KN/m ²]	γ [KN/m ³]	δ [o]	c [KN/m ²]
1. Blue-gray clay mud	10.42	750	17.1	6 ^o	4.1
2. Brown-gray clay with sand	16.76	1650	18.3	9 ^o	11.16
3. Brown-gray clay mud	18.82	266	17.2	9 ^o	1.4
4. Soft plastic clay	4	2200	18.7	14 ^o	20.2
5. Small solid sand	15	7420	20.4	34 ^o	0

- Size of casing pipe: d = 1220mm, D=1300mm, L = 50m, hp = 3m.
- Base machine HS 833 HD produced by Liebherr brand with specifications is expressed as: two internal combustion engines: the first one is D924 TI-E Model with the capacity of 125kW which is used for the transmitting hydraulic pump with flow 1931/min; the second one is D926 TI-E Model with the capacity of 210kW which is used for driving two hydraulic pumps with total flow 4281/min and working pressure 30Mpa. This type of the base machine has an hydraulic circuit with the connector used for the driving equipment casing pipe, including two connectors: the connector with the capacity P_x = 160kW used for the transmitting rotating mechanism and the connector with the capacity P_e = 40kW for the driving pressing mechanism.

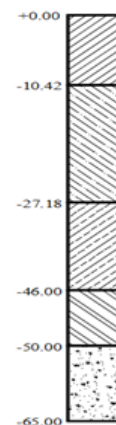

Figure 7: Geological sections

Calculation results:

By applying the method in section 2 with Δα = 1, m=85, α1 =50 and running on the background of C++ and Excel programme, the detailed calculation is stated in document [12]. The graph of resistance force N, M according to α is illustrated in Figure 8, and the parameters of the reasonable working regime of the working equipment are listed in Table 3. The parameters of the reasonable working regime are determined in the range of the specifications of the equipment produced by famous brand.

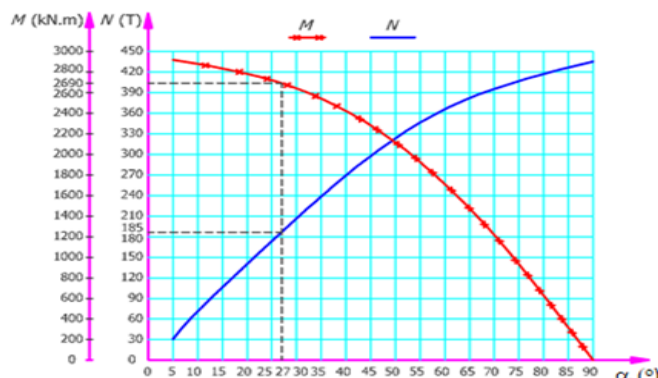

Figure 8: The diagram of resistance force M, N according to α of P6 pillar's My Thuan bridge (Vietnam)

Table 3: Parameters of the reasonable working regime of working equipments

Parameters	α _{hl} [Degree]	M [KN.m]	N [Ton]	n [rpm]	v _d [m/min]	P _E [kW]	P _x [kW]
Values	270	2690	185	0.48	1	38.5	160

CONCLUSIONS

By using the specialized knowledge and achievements in moving equipment fields, the research paper has been successfully determined the the reasonable working regime of working equipments used for lowering steel casing pipe to construct bored piles by the RPM on the weak ground with a given base machine. This is a necessary step for designing working equipments used for lowering casing pipe with the given base machine to reduce the cost of buying machine and increase economic efficiency. The developed method can be also used for determining the reasonable working regime of working

equipments during the process of penetrating casing pipe through many layers of the ground with different resistance forces. This leads to maximize the capacity of driving source and improving working capacity of the equipment in various conditions. Based on the developments, an automatic software used for calculating the reasonable working regime of equipments can be extended to apply in the operation and exploitation process of equipment.

REFERENCES

1. Liebherr Germany. Casing rotator, from <https://www.liebherr.com/shared/media/construction-machinery/deep-foundation/pdf/flyer/liebherr-casing-oscillator-deep-foundation-en.pdf>.
2. Soilmec Italy. Hydraulic casing rotator, from <http://www.reddeerpiling.com/wp-content/uploads/2015/06/VRMKLRDM.pdf>.
3. Nippon Sharyo Japan. Casing rotator supertop, from https://www.n-sharyo.co.jp/business/kiden_e/casing.html.
4. Lehane BM., Schneider JA., Xu X., (2005). The UWA-05 method for prediction of axial capacity of driven piles in sand. Proceedings of the International Symposium on Frontiers in Offshore Geotechnic 2005, p.683–689. (DOI:10.1201/NOE0415390637.ch76).
5. Xu X., Lehane BM., Schneider JA., (2005). Evaluation of end-bearing capacity of open-ended piles driven in sand from CPT data. Proceedings of the International Symposium on Frontiers in Offshore Geotechnics 2005, p. 725–731. (DOI:10.1201/ noe0415390637.ch82)
6. Kempfert HG. (2010). Tragverhalten von offenen Verdrängungspfählen unter Berücksichtigung der Pfrödfenbildung in nichtbindigen Böden. Schriftenreihe Geotechnik Universität Kassel, Kassel Germany.
7. TCVN 9352-2012 (2012). Soils - Method of cone penetration test (CPT), Ministry of Science and Technology Vietnam.
8. TCVN 9846-2013 (2013). Standard test method for piezocone penetration testing of soils (CPTu), Ministry of Science and Technology Vietnam.
9. Donald W. Taylor (1948). Fundamentals of soil mechanics. Wiley, New York.
10. B.E. Nikolaevich, B. I. Nyrgaiazovich, Z.S. Sergeevich (2015). Enhancing the stability of the timber harvesting machine of manipulator type by using an active suspension system, Journal of Applied Engineering Science, 13(2015)1, 319, 111 – 116, DOI:10.5937/jaes13-7652
11. Chinh VL., Dung PQ., Thanh TQ., (2002). Design Basis for Construction Machine, Construction Publisher Vietnam.
12. Minh PV. (2019). Studying the calculation method, designing the working structure of the pipe-laying equipment for bored piles in soft ground, Science research project, Code number, B2017-XDA-13, Ministry of Education and Training Vietnam.

Paper submitted: 07.08.2021.

Paper accepted: 20.10.2021.

*This is an open access article distributed under the
CC BY 4.0 terms and conditions.*