

ALGORITHMS AND SOFTWARE OF WHITENING OF NOISE IN THE RECEPTION OF BROADBAND CHIRP SIGNALS IN THE HF COMMUNICATION CHANNEL

Vladimir Ivanov*

Volga State University of Technology, Yoshkar-Ola, Russia

Dmitriy Ivanov

Volga State University of Technology, Yoshkar-Ola, Russia

Natalya Ryabova

Volga State University of Technology, Yoshkar-Ola, Russia

Maria Ryabova

Volga State University of Technology, Yoshkar-Ola, Russia

Andrei Chernov

Volga State University of Technology, Yoshkar-Ola, Russia

Alexey Elsukov

Volga State University of Technology, Yoshkar-Ola, Russia

Scientific substantiation of the adaptive noise whitening algorithm is given in the HF band when receiving a continuous chirp signal. The software implementation of the algorithm is presented. Full-scale experiments were conducted, using the developed device with a continuous chirp signal, based on the technology of software-defined radio systems. It is established that whitening tends to equalize noise level throughout the HF band. Some rare emissions of whitening spectrum do not exceed the range of 10 dB.

Key words: Computer science, Software, Whitening of noise, HF communication channel

INTRODUCTION

It is well-known that the development of computers has led to the fact that the mathematical operations in electronic devices become fulfilled by means of discrete mathematics [12, 03]. This provides significantly higher precision math operations. Under these conditions, the task of creating new devices is transferred to programming. The creation of universal hardware platform, implementing software and RTS with different functionalities is of particular importance. This technology is called SDR. Extensive use of SDR technology provides versatile family of programmable transceivers (USRP), Company Ettus Research [04] configurations with different frequency bands and supports for control and programming software such as GNU Radio, NI LabVIEW, MathWorks Matlab, HSDR and others. Functionality of some communication, radar and radio sounding systems [04], implemented on the platform USRP, have been researched and were found promising. Unresolved urgent

scientific challenge is to program implementation and research on the platform devices that perform other functions. In particular, the adaptive filters for more effective rehabilitation of HF communication systems and ionosphere sensing in a wide frequency band.

That's why the aim of this paper is the scientific study of the adaptive noise whitening algorithm in the HF band in the reception of a continuous chirp signal, its program implementation and experimental research using the platform USRP.

ALGORITHM OF ADAPTIVE WHITENING WHEN RECEIVING CONTINUOUS CHIRP SIGNAL

Predominant concentrated interference and fluctuation noise of various origins are in the HF band. The received signal including the channel fluctuation noise and concentrated interference can be represented as:

$$y(t) = u_R(t) + \sum_{k=1}^{k_0} n_k(t) + n_0(t) = u_R(t) + n(t) \quad (1)$$

* Volga State University of Technology, The Republic of Mari El, Yoshkar-Ola, pl. Lenina 3, 424000 Russia; IvanovVA@volgatech.net

where $u_R(t)$ - complex (broadband) signal; $n_k(t)$ - Narrow-band (centered) noise; $n_0(t)$ - quasi-white noise.

Similar relations will have a place for the complex amplitudes of the signals (2):

$$Y_R(t) = U_R(t) + \sum_{k=1}^{k_0} N_k(t) + N(t) = U_R(t) + N(t) \quad (2)$$

In this case, the complex amplitude spectrum of noise and signal mixture can be written:

$$Y_R(j\omega) = U_R(j\omega) + \sum_{k=1}^{k_0} N_k(j\omega) + N_0(j\omega) \quad (3)$$

where

$$|N_k(j\omega)| = N_k(\omega) = N_k \cdot \delta(\omega - \omega_k) = \begin{cases} N_k, & \text{if } \omega = \omega_k \\ 0, & \text{if } \omega \neq \omega_k \end{cases}$$

Mathematical model record

$$|N_k(j\omega)| = N_k \cdot \delta(\omega - \omega_k)$$

may be used for the spectrum of centered interference.

Sensing of multidimensional ionospheric radio channel is carried out by continuous chirp signal, and its element has the duration T_e with a medium frequency $\bar{\omega}$:

$$x_T(t) = \cos(\bar{\omega}t + \frac{\beta}{2}t^2) \quad (4)$$

where

$$\beta = \dot{\omega} = \frac{d\omega}{dt} = 2\pi \frac{df}{dt} = 2\pi \dot{f}$$

- is the rate of angular frequency change,

$$t \in \left[\bar{t} - \frac{T_e}{2}, \bar{t} + \frac{T_e}{2} \right]$$

Obviously, the corresponding complex amplitude of the signal is:

$$X_T(t) = \exp(j\frac{\beta}{2}t^2) \quad (5)$$

And its power spectrum at a large time-bandwidth product:

$$|X_T(j\omega)|^2 = \frac{2\pi}{\dot{\omega}} = \frac{1}{\dot{f}} \quad (6)$$

In this case, the power spectrum of the element of the received signal can be written as:

$$|U_R(j\omega)|^2 \approx \frac{\kappa_R^2(\omega)}{\dot{f}} \quad (7)$$

Where $\kappa_R^2(\bar{\omega})$ - is a constant depending on signal power attenuation at the central frequency element as it propagates from the transmitter to the receiver.

Recall that if a function

$$|U(j\omega)|^2 = \text{Re}^2 U(j\omega) + \text{Im}^2 U(j\omega)$$

is a power spectrum of the signal, then

$$|U(j\omega)|^2 / T_e = U^2(\omega) / T_e - \text{is its SPM.}$$

Consider a mixture of signal and noise on the element range

$$\omega \in \left[-\frac{W_e}{2}, \frac{W_e}{2} \right] \text{ or } f \in \left[-\frac{B_e}{2}, \frac{B_e}{2} \right]$$

where $W_e = 2\pi B_e$ - is the signal frequency band.

This element can be considered as a time window defining the sampling time for extended processing of the signal and noise. This window will correspond to the average value of the time \bar{t} . For a sequence of samples will have a sequence of averages $\bar{t} = \{ \bar{t}_1, \bar{t}_2, \dots, \bar{t}_p, \dots, \bar{t}_n \}$.

Suppose that for calculating the power spectral density of the signal and noise, we use FFT. The calculation result in this case can be regarded as the result of signal passing through a "comb" of narrow band pass filters, called bins. Each of these passes on the output signal of the energy, corresponds to the band B_b bin, which is equal $B_b = 1/T_e$. For a model of noise and interference that we have adopted in a sequential enumeration sample, interference signals will always occupy the same beans, and chirp signal in time will consistently move from one bean to another. Therefore, the sum of all sample spectra of the interference power at the output of its employees bins will accumulate while the power chirp signal will not accumulate. According to this reasoning, the result of the summation will be:

$$\sum_{p=1}^n \frac{N_{0p}^2(\omega)}{T_e} + \sum_{p=1}^n \sum_{k=1}^{k_0} \frac{N_k^2(\bar{t}_p) \cdot \delta(\omega - \omega_k)}{T_e} + \sum_{p=1}^n \frac{\kappa_R^2 \cdot \delta(\omega - \omega_p)}{T_e \sqrt{\dot{f}}} = n \cdot K^2(\omega) \quad (8)$$

Where

$$\kappa_R^2(\omega) = \kappa_R^2 \cdot \delta(\omega - \omega_p) = \begin{cases} \kappa_R^2, & \text{if } \omega = \omega_p \\ 0, & \text{if } \omega \neq \omega_p \end{cases}$$

The division of the right and left sides of the equation to give us the amount of the average values of power density, and extraction of the square root correction function:

$$K(\omega) = \sqrt{\frac{\langle N_0^2(\omega) \rangle}{T_e} + \sum_{k=1}^{k_0} \frac{\langle N_k^2 \rangle}{T_e} \cdot \delta(\omega - \omega_k) + \frac{1}{n} \sum_{p=1}^n \frac{\kappa_R^2}{T_e \sqrt{\dot{f}}} \cdot \delta(\omega - \omega_p)} \quad (9)$$

Multiply the current sample of spectrum of signals mixture (3) by a factor $1/K(\omega)$ and it will cause a correction equivalent equalizing. Since the averaging in (8) leads to suppression in n times of the last term under the square root sign at frequencies where it is not equal to zero, equalizing based on a function $1/K(\omega)$ will "whiten" the spectrum of received interference.

Note that if the averaging time $T=n*T_e$ is less than the coherence time of the radio channel, it can be assumed that the quasi-white noise is δ correlated to the time $[\bar{t}_n - \bar{t}_1]$ and that the range of concentrated interference is virtually unchanged. Therefore, the function

$$\frac{\langle N_0^2(\omega) \rangle}{T_e} = \frac{n_0}{2}$$

- is power spectral density of quasi-white noise and power spectral density of arbitrary interference concentrated equals

$$\frac{\langle N_k^2 \rangle}{T_e} = \frac{N_k^2}{T_e}$$

Consider the results of equalizing of bins with different center frequencies. This primary bins with midrange $\omega = \omega_k$ loaded lumped noise. For them, the third term in equation (9) can be neglected. For comparison of the first and second terms, experimental data presented as a typical case in Figure 1, must apply. Here is a selective spectrum of signals present in the HF range when receiving continuous chirp signal. In this case, a useful chirp signal is masked by the plurality of receiving it, focusing on the interference range (vertical lines). In addition, the level of concentrated interference significantly exceeds the level of fluctuating noise.

These data allow us to conclude that for bins with midrange $\omega = \omega_k$ (loaded lumped interference), noise level fluctuation can be ignored and used to estimate the inequality:

$$n_k^2(\omega) \gg \frac{n_0}{2} \quad (10)$$

where $\frac{\langle N_k^2 \rangle}{T_e} = \frac{N_k^2}{T_e}$.

So for them, correcting function obtained by averaging, is as follows:

$$K(\omega) = \sqrt{\sum_{k=1}^{k_0} \frac{\langle N_k^2 \rangle}{T_e}} \cdot \delta(\omega - \omega_k) \quad (11)$$

Multiplication in this case the current sample mixture spectrum signal and noise $X_R(j\omega)$ at the points $\omega = \omega_k$ on $1/K(\omega)$ will result to suppressing localized interference in these points and thereby to whiten of their spectrum:

$$|\hat{Y}_R(j\omega)| = \frac{|Y_R(j\omega)|}{K(\omega)} = \frac{Y_R \cdot \delta(\omega - \omega_k)}{K(\omega) \cdot \delta(\omega - \omega_k)} \approx 1 \quad (12)$$

It is obvious that the output bins with medium frequency $\omega \neq \omega_k$ and $\omega \neq \omega_p$ will be present only as fluctuation noise. For them, the correction function is:

$$K(\omega) \approx \sqrt{\frac{n_0}{2}} \quad (13)$$

For samples of this sample mixture spectrum signal and noise, adjusted to these points, we get:

$$|\hat{Y}_R(j\omega)| = \frac{|Y_R(j\omega)|}{K(\omega)} = \frac{Y_R(\omega)}{K(\omega)} \approx 1 \quad (14)$$

Separately it is necessary to consider the case for the bins to medium frequency $\omega \neq \omega_k$, but $\omega = \omega_p$. They contain the output fluctuation noise and element of continuous chirp signal corresponding to the presence of the latter in a single comb filter analyzer.

Let the averaged spectrum chirp signal level due to large decreases in the values so that at points the following inequality holds:

$$\frac{n_0}{2} \cdot \delta(\omega - \omega_p) \gg \sum_{p=1}^n \frac{1}{n} \frac{\kappa_R^2}{T_e \sqrt{f}} \cdot \delta(\omega - \omega_p) \quad (15)$$

Thus, in this case, the correction function of the points $\omega = \omega_p$ can be approximately represented as:

$$K(\omega) \approx \sqrt{\frac{n_0}{2}} \cdot \delta(\omega - \omega_p) \quad (16)$$

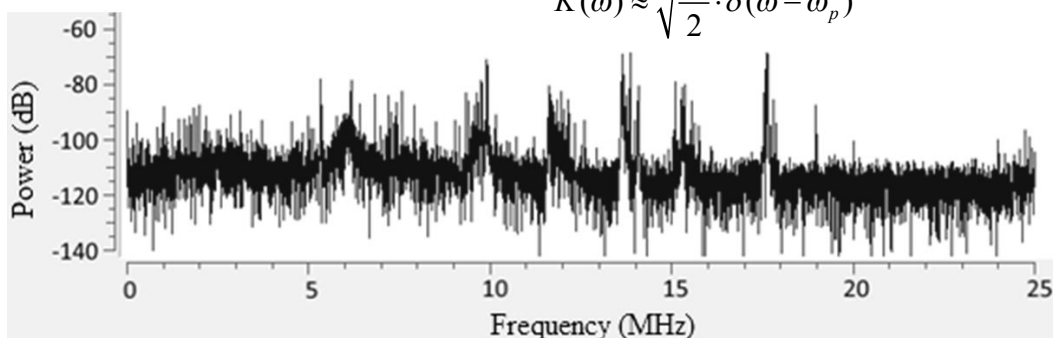

Figure 1: Instantaneous frequency spectrum of received power in the band of 25 MHz signals: continuous chirp, fluctuation noise and concentrated interference (vertical bars)

Equation (16) coincides with formula (13). Therefore, by correcting these points obtain a spectrum of the form (14).

The resulting algorithm can be expressed as the block diagram shown in Figure 2. Whitening equalizer based on the FFT. Sample spectra of a mixture of the received signals received at intervals equal to the time of analysis T_e , the frequency resolution of the spectrum is $B_b = 1/T_e$. Analysis immediately subjected to a range of frequencies approximately equal to the HF bands.

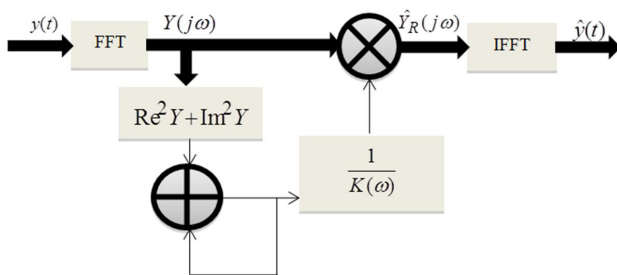

Figure 2: The algorithm of adaptive whitening interference on HF

The scheme branch that goes down, forms a corrective function $1/K(\omega)$. Due to the multiplication of the current sample spectrum on the corrective function is its whitening, and the inverse Fourier transform you back to the time domain, with a mixture of white noise and useful chirp signal. Correction function is obtained by averaging n over successive sampling power spectra. As a result, each new sample for the correction function will get through the averaging time equal $T = n * T_e$. Adaptation is that the algorithm takes into account changes over time average spectrum whitewashes the interference by its periodic (with a period T) update. Thus there is a periodic update and corrective functions.

In this case, the frequency of chirp signal varies slowly with time. The procedure for computing constructed so that during T_e the sampling range of continuous chirp signal will occupy only one bin with the strip B_b . Therefore, for the time of spectrum averaging n it will take n consecutive bins. The spectrum of the corrected current sample will contain the bin of chirp signal at a higher average rate. Therefore, the frequency band of the spectrum averaged chirp signal will not interfere with bandwidth bin corrected spectrum and, therefore, will not affect him at whitening.

Parameters B_b and n , as well as during the change of the correction functions are selected on the basis of the available experimental data in the literature on the prevailing frequency band centered noise and HF radio channel coherence time.

RESULTS OF FIELD EXPERIMENTS TO STUDY OF ALGORITHM THE ADAPTIVE WHITENING

Experiments were carried out with the help of the developed [04, 10] device with continuous chirp signal based on the technology and software configurable radio (SDR). Use a universal platform is instrumental USRP [04].

Figure 3 shows the appearance of the device and a block diagram of synthesis algorithms and processing of continuous probing chirp signal by compression method in the frequency domain [08, 01].

The device operates in the HF range and used for ionospheric sounding of telecommunication channels. The frequency of the signal changes at a rate of 50-500 kHz / sec, running continuously between 2 and 30 MHz [03, 10, 11]. The received signal is digitized, and its range is transferred to the frequency range [-12.5; 12.5] MHz.

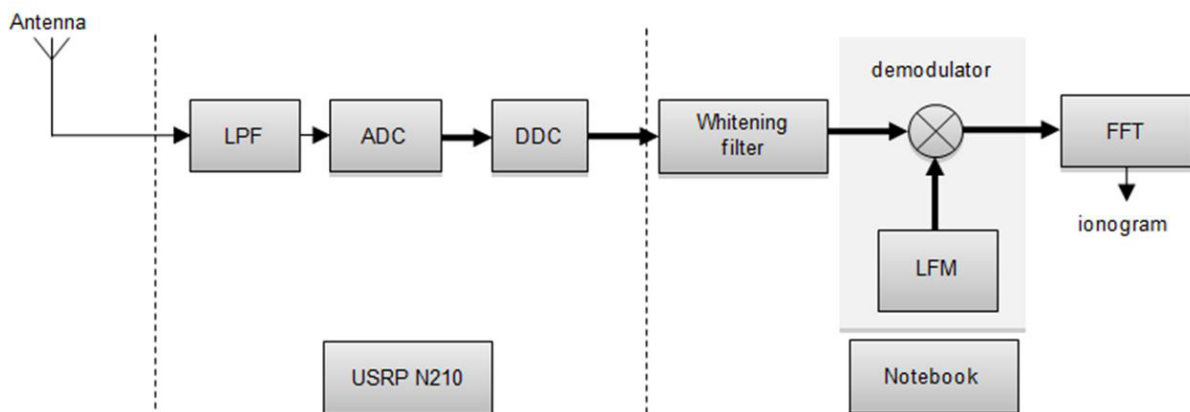
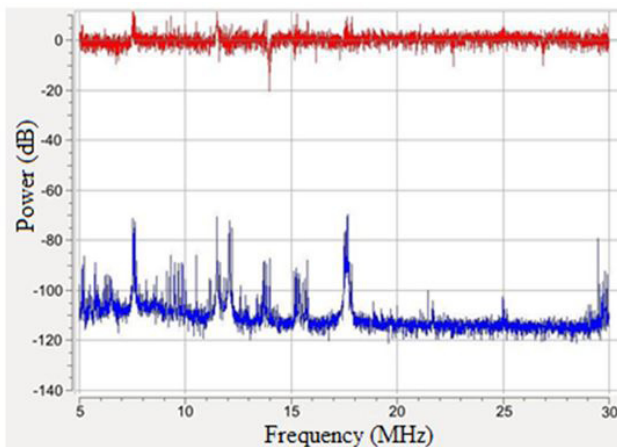

Figure 3: Block diagram of synthesis algorithms and processing continuous chirp signal

What is new is the use of adaptive whitening filter, the main function of which is to suppress the interference of powerful concentrated, which is implemented according to the above algorithm.

The studies were conducted in Yoshkar-Ola city (Russia). These included two stages. On the first - antenna receives the signal interference. Analyze them whitening in terms of concentrated interference suppression and equalization of fluctuation noise [11]. In the second stage with a noise of generator added chirp signal from synthesizer device, allowing us to alter its level in relation to the level of noise simulating fluctuating background noise.

Figure 4 shows the typical results of the first stage. In instant spectrum, marked in blue, there are two effects. This powerful concentrated interference (vertical lines), the level of which exceeds the level of fluctuation noise up to 40 dB. In addition, there is a decrease with increasing frequency fluctuation noise level.



(a)

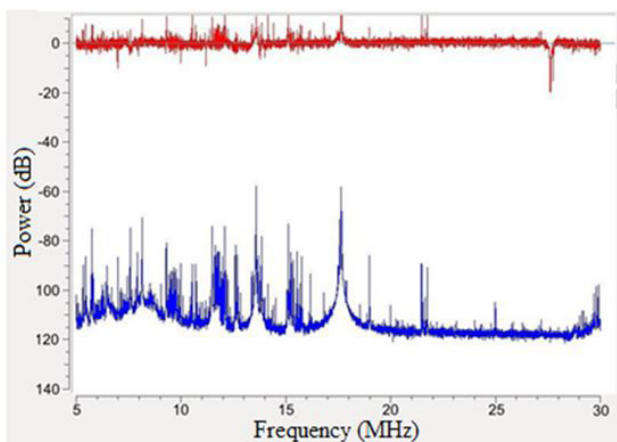

(b)

Figure 4: Two typical instantaneous noise spectrum (case a, b) of HF band before (blue) and after whitening (red)

We see that the whitening tends to equalize the level of interference in all HF bands. It is localized to about 0 dB, which confirms the results of the theoretical analysis. Some rare emissions of white-wash spectra do not exceed the range of 10 dB.

Figure 5 shows the results of the second stage. It is evident that in excess of a certain level of chirp signal (20 - 25 dB) when in formula (9) the first and third terms are comparable, manifested influence on whitening the desired signal.

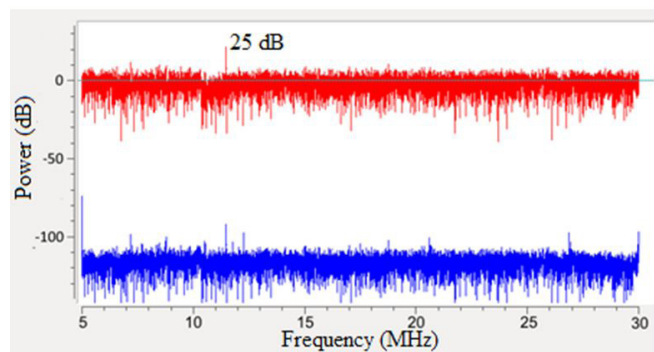

Figure 5: Results of whitening interference with chirp signal level less than 25 dB of the fluctuation noise.

CONCLUSIONS AND FUTURE WORKS

Scientific substantiation is given of the adaptive noise whitening algorithm in the HF band when receiving a continuous chirp signal. The software implementation of the algorithm is presented. Full-scale experiments using the developed device with a continuous chirp signal based on the technology of software-configurable radio systems is performed. It is established that whitening tends to equalize interference level throughout the HF band. Some rare emissions of whitewash spectra do not exceed the range of 10 dB. In the future we plan to conduct experiments to investigate the effectiveness of whitewash in the case of large levels of chirp signal.

This work was supported by grants RFBR: projects № 13-07-00371; 13-02-00524; 15-07-05280; 15-07-05294; Grants Ministry of Education of the Russian Federation № 3.2695.2014 / K, № 8.2697.2014 / K, № 2276, № 2247; RNF № 15-19-10053.

REFERENCES

- 1) Cannon, P.S., Angling, M.J., Davies, N.C., et al, (2000) DAMSON HF channel characterization – a review. Proc. MILCOM, Vol. 1, 59-64.
- 2) Gherm, V.E., Zernov, N.N., Strangeways, H.J., (2002) Multipath Effects in Wideband Fluctuating HF Channels. Acta Geofizika e Geod. Geoph., Hungary, Vol. 37, No. 2-3, 253-259.
- 3) Grozov, V.P., Kurkin, V.I., Ponomarchuk, S.N., (2012) The techniques for processing and interpretation of ionosphere sounding data using the continuous chirp signal. Physical Bases of Instrumentation, Vol. 1, No. 3 (4), 33-41.
- 4) Ivanov, D.V., Ivanov, V.A., Ryabova, N.V., Elsukov, A.A., Ryabova, M.I., Chernov, A.A., (2013) SDR-ionosonde with continuous LFM-signal on the platform USRP. Vestnik of Volga State University of Technology. Series “Radio Engineering and Infocommunication Systems”, Vol. 19, No. 3, 80-93.
- 5) Ivanov, V.A., Ivanov, D.V., Ryabova, N.V., Chernov, A.A., (2013) Multidimensional high-frequency radio channel and experimental studies of its main characteristics. Electromagnetic Waves and Electronic Systems, Vol. 18, No. 8, 40-48.
- 6) Ivanov, V.A., Ivanov, D.V., Ryabova, N.V., Maltsev, A.V., Ryabova, M.I., Tzarev, I. Ye., (2008) Ionospheric high-frequency communication channels sounding from the earth surface. Vestnik of Volga State University of Technology. Series “Radio Engineering and Infocommunication Systems”, Vol.2, No. 1, 3-20.
- 7) Ivanov, V.A., Kurkin, V.I., Nosov, V.E., Uryadov, V.P., Shumaev, V.V., (2003) Chirp ionosonde and its application in the ionospheric research. Radiophysics and Quantum Electronics, Vol.47, No. 11, 919-952.
- 8) Kryukovsky, A.S., Zaichikov, I.V. (2008) Features of radiopulse propagation in media with dispersion. Electromagnetic Waves and Electronic Systems, Vol.13, No. 8, 36-41.
- 9) Le Roux, Y. M., Niberon, M., Fleury, R., et al, (1990) HF channel modeling and simulation. IEE Radio Receivers and Associated Systems 5th conf., Cambridge, 72–76.
- 10) Maslin, N.M., (1987) HF communications: a systems approach. London.: Pitman Publishing.
- 11) Shinakov, Yu.S., (2013) Power spectral density of interference caused by nonlinear distortions in devices with amplitude-phase conversion. Journal of Communications Technology and Electronics, Vol. 58, No. 10, 1024-1034.
- 12) Vierinen, J., (2012) On statistical theory of radar measurements. Doctoral dissertation. Aalto University, Helsinki

Paper sent to revision: 23.10.2015.

Paper ready for publication: 14.12.2015.