

COMPONENT SIZING AND ENERGY MANAGEMENT FOR A SERIES HYBRID ELECTRIC TRACKED VEHICLE

Stefan V. Milićević^a, Ivan A. Blagojević^b

^aUniversity of Belgrade, Faculty of Mechanical Engineering,
Department for Motor Vehicles, Belgrade, Republic of Serbia,
e-mail: stefanm9670@gmail.com, **corresponding author**
ORCID iD:  <https://orcid.org/0000-0003-4837-9067>

^bUniversity of Belgrade, Faculty of Mechanical Engineering,
Department for Motor Vehicles, Belgrade, Republic of Serbia,
e-mail: iblagojevic@mas.bg.ac.rs,
ORCID iD:  <https://orcid.org/0000-0002-5776-5990>

DOI: 10.5937/vojtehg70-39762; <https://doi.org/10.5937/vojtehg70-39762>

FIELD: Mechanical engineering

ARTICLE TYPE: Original scientific paper

Abstract:

Introduction/purpose: The paper presents a systematic approach to the development of a series hybrid electric tracked vehicle (HETV) including powertrain sizing and adequate energy management strategy (EMS) selection.

Methods: Powertrain elements were sized considering key performance requirements. Three energy management strategies were proposed: Thermostat Control Strategy (TCS), Power Follower Control Strategy (PFCS), and Optimal Power Source Strategy (OPSS). The evaluation of the powertrain configuration and the three proposed EMSs was performed in the Simulink environment using a driving cycle containing significant acceleration, braking and steering.

Results: The results showed that the OPSS proved to be the best due to increased fuel economy and a low battery state of charge (SOC) variation. Compared to the previous research of the same vehicle with a parallel hybrid configuration, significantly better results were achieved. The investigation of the results indicates that the proposed powertrain and control strategy offer 53.79% better fuel economy which indicates that the powertrain sizing was properly performed.

Conclusions: The results of this work are of great importance for understanding the effect of proper powertrain sizing on fuel economy. Compared to the reference vehicle, the proposed configuration achieves significant improvement, most of which is attributed to adequate sizing. The OPSS proved to be the best strategy, thus confirming the theoretical hy-

pothesis. The series hybrid configuration with the OPSS as the EMS proved to be a major candidate for use in HETVs.

Key words: tracked vehicle, hybrid electric vehicle, energy management, control strategy, fuel economy.

Introduction

Hybrid drive is the most practical and realistic alternative to conventional transmission at the moment ([Jimenez-Espadafor et al., 2011](#); [Ehsani et al., 2018](#)). In the field of wheeled vehicles, hybrid propulsion systems have been very common for many years ([Hannan et al., 2014](#)). On the other hand, due to different technological and economical reasons, the research of hybrid technology for tracked vehicles has not been the focus of many researchers. However, in the last decade, the defense industry started showing interest in the military vehicle hybridization ([Rizzo, 2014](#)) and hybrid electric tracked vehicles (HETVs). Hybrid drive for HETVs offers advantages such as better fuel economy, additional onboard electric power, silent watch capability and decreased noise and thermal signature ([Khalil, 2009](#)).

In ([Galvagno et al., 2012](#)), the authors presented a mathematical model and a dynamic analysis of a single-drive series hybrid tracked tank, while in ([Zou et al., 2012a](#)) the authors developed *bi-level* optimization consisting of two nested optimizations, one for optimal powertrain sizing, and the other one for optimal power management of the HETV. In ([Liu et al., 2015](#); [Zou et al., 2016](#)), a control-oriented model of an HETV was developed and the EMS based on reinforcement learning was proposed, which achieved results comparable to dynamic programming, while the authors in ([Ran-dive et al., 2019, 2021](#)) presented a systematic approach to powertrain sizing which reduced transmission weight by 16% and proposed a novel rule-based strategy which achieved over 30% better fuel economy when compared to the previous original powertrain.

Research on the topic of hybrid propulsion has also appeared in Serbian military circles. Driven by the idea of achieving better performance and less fuel consumption with minimal changes to the original conventional transmission, in ([Milićević & Muždeka, 2021](#)) the authors proposed a conceptual hybridization model of the Serbian infantry fighting vehicle BVP M80A. In this paper, the performance of the vehicle was analyzed, and the later research ([Milićević et al., 2021](#)) proposed an energy management strat-

egy (EMS) based on the Power Follower Control Strategy (PFCS) which achieved 12.8% better fuel economy than conventional transmission, and even better result (23.2%) was achieved with introducing additional generator in the powertrain. These two research studies laid the foundation to hybridization of the BVP M80A, the former focusing on conceptualization of hybrid powertrain and the latter focusing on improving efficiency of the designed powertrain. The constraints set in the first research study led to the complex powertrain and very complex multi-mode EMS designed in the second one. The motivation for this work stems from the mentioned fact. The aim of this paper is to design a series hybrid powertrain which would be efficient and simple by considering key performance requirements, proper sizing of all powertrain elements and adequate selection of an EMS.

Proposed powertrain configuration

The most common configuration in HETVs is series (Zou et al., 2012b; Zhang et al., 2020; Randive et al., 2019; Qin et al., 2018; Randive et al., 2021; Zou et al., 2016). The lack of shafts, gears and other mechanical elements is very important from the aspect of reliability and better utilization of space. The increased power rating of battery offers more onboard electric power. These advantages and the possibility of increased fuel economy were the main factors for the proposed series configuration. The major components of the proposed configuration are (Fig. 1):

1. Traction motors,
2. Simple two-stage transmission,
3. Engine-generator unit, and
4. Energy storage.

The proposed powertrain adopts a dual-drive variant of the series configuration. Two traction motors independently drive the two sprockets, a generator is driven by the diesel engine which is a primary source of energy (PS) while the battery pack supplies or absorbs energy when needed and acts as a secondary source (SS). Between the electric motor and the wheels there is a simple two-speed transmission. Compared to the reference vehicle and the parallel configuration designed in (Milićević & Muždeka, 2021), this powertrain is much simpler. It has no planetary gear sets and no complex gearbox. Lack of the engine-sprocket mechanical

connection enables the engine to work at the optimal operating point which is the main advantage of this configuration.

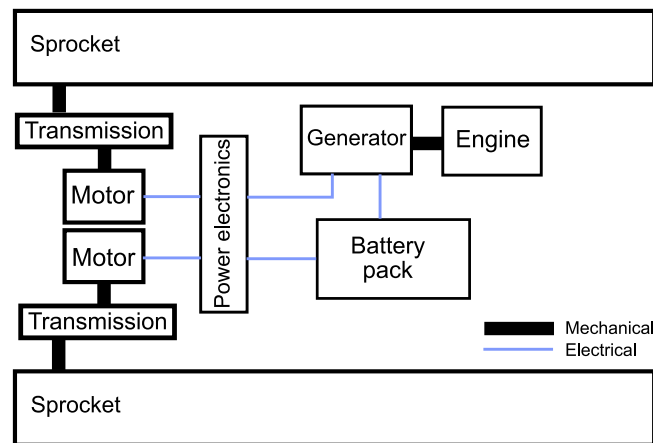

Figure 1 – Proposed powertrain configuration

Рис. 1 – Предлагаемая конфигурация гибридного привода

Слика 1 – Предложена конфигурација хибридног погона

Component sizing

The main rationale of the hybrid drive concept shown in (Milićević & Muždeka, 2021) was as few changes to the transmission as possible. Therefore, the authors of the aforementioned research retained numerous parameters of the initial transmission, and the parameters of the battery and the electric motor were adapted to the initial system parameters. Such approach to sizing certainly results in an unbalanced and disproportionate powertrain. Due to their specific purpose, tracked vehicles have unique requirements, such as high gradeability, off-road mobility and satisfactory skid-steering and acceleration performance. The design of the HETV powertrain should be made based on a critical performance analysis, something that is rarely done in literature (Randive et al., 2019). Based on the analysis, the adequate sizing of the components can be done to achieve satisfactory performance.

Power and torque demand

Movement resistances have a complex nature and depend on the type and slope of the terrain, pressure distribution, turning radius, etc. For this

paper, the simplest case of movement on hard terrain will be considered. To propel the wheels of the HETV in a straight-line motion, traction force F_{tr} has to be equal to the sum of various resistances as follows:

$$F_{tr} = F_{rol} + F_{aero} + F_{grade} + F_{in}, \quad (1)$$

where F_{rol} , F_{aero} , F_{grade} , F_{in} are rolling resistance, aerodynamic resistance, road grade resistance and inertial force, respectively. These forces are given as follows:

$$\begin{aligned} F_{rol} &= f m_v g \cos \alpha \\ F_{aero} &= \frac{1}{2} C_d A \rho v^2 \\ F_{grade} &= m_v g \sin \alpha \\ F_{in} &= \delta m_v a \end{aligned} \quad (2)$$

where f is the coefficient of the rolling resistance, m_v is the vehicle curb weight, α is the road slope angle, C_d is the aerodynamic resistance coefficient, A is the vehicle frontal area, ρ is the air density, V is the vehicle speed, δ is the mass coefficient and a is the vehicle acceleration.

During turning, the vehicle needs to overcome additional turning resistances which are obtained as (Wong, 2022):

$$M_R = \frac{1}{4} \mu m_v g L \quad (3)$$

where μ is the coefficient of the lateral resistance and L is the contact length of the track. The coefficient μ is calculated as:

$$\mu = \mu_{max} (0.925 + 0.15R/B)^{-1} \quad (4)$$

where μ_{max} is the maximum value of μ , B is the vehicle tread and R is the turning radius. The turning radius can be calculated from the equation:

$$R = \frac{B}{2} \frac{\omega_2 + \omega_1}{\omega_2 - \omega_1} \quad (5)$$

where ω_1, ω_2 are the sprocket angular velocities.

Power demand is obtained by multiplying the sum of the resistance forces with the vehicle velocity:

$$P_{req} = F_{tr}V + M_R\omega. \quad (6)$$

The maximum power is required during the maximum acceleration. Assuming acceleration on the level ground, the power required is given as:

$$P_{max} = (fm_vg + \frac{1}{2}C_dA\rho v^2 + \delta m_v a)V_f, \quad (7)$$

where V_f is the final vehicle speed.

The maximum torque is determined based on the gradeability requirements. On a slope, at a constant low speed, the vehicle must overcome road grade resistance and rolling resistance as follows:

$$F_{gra,max} = (fm_vg \cos \alpha + m_vg \sin \alpha). \quad (8)$$

The required torque is expressed as:

$$T_{max} = F_{gra,max} \cdot r = (fm_vg \cos \alpha + m_vg \sin \alpha) \cdot r, \quad (9)$$

where r is the sprocket radius.

The performance requirements and the vehicle parameters are given in Table 1.

Table 1 – Overview of the vehicle parameters
Таблица 1 – Обзор характеристик машины
Табела 1 – Преглед параметара возила

Parameter	Value	Parameter	Value
Vehicle mass m [kg]	13850	Sprocket radius r [m]	0.2577
Track contact length L [m]	3.3	Vehicle tread B [m]	2.526
Vehicle frontal area A [m ²]	5.4	Drag coeff. C_d [-]	1.1
Air density ρ [kg/m ³]	1.2258	Rolling resistance coeff. f [-]	0.07
Maximum gradeability [%]	60	Maximum speed V_{max} [km/h]	65
Maximum acceleration	0-32km/h in 8s	Silent watch autonomy [km]	25

Transmission

Most of electric and series electric hybrid vehicles have a single-stage transmission between the traction motor and the wheel (or the final drive) due to high efficiency and a favorable torque curve of the electric motor (Wu et al., 2013). However, with HETVs, the required power and torque performances are in relative disproportion, so it is difficult to find an electric motor with a sufficiently broad operating range. In addition, it was shown that the dual-stage transmission for HETVs is significantly more efficient than single-stage (Randive et al., 2021). The adopted gear ratios depend on the maximum torque and the maximum required speed of the vehicle, and have a direct impact on the sizing of the traction motor. The minimum gear ratio must meet the condition of gradeability, that is:

$$i_{min} \geq \frac{1}{2} \frac{F_{grade,max} \cdot r}{T_{m,peak}}, \quad (10)$$

where $T_{m,peak}$ is the peak torque rating of the two traction motors. On the other hand, the maximum gear ratio must meet the condition of simultaneously achieving the maximum speed of the traction motor and the vehicle, that is:

$$i_{max} \leq \frac{\omega_{EM,max}}{V_{max}/r}, \quad (11)$$

where $\omega_{EM,max}$ is the maximum speed of the traction motor.

Traction motor

The maximum power and the torque rating of the two traction motors need to satisfy performance requirements expressed with Eq. (7) and Eq. (8). The combined maximum power of the two traction motors should be equal to or greater than the maximum power required P_{max} . The maximum and rated torque must be sufficient to satisfy gradeability performance and to enable continuous and smooth motion at the maximum speed, respectively. Adopting the data from Table 1, and substituting into Eq. (7) and Eq. (8), the maximum required power of $P_{req} = 227.34kW$ and the maximum required torque of $20113Nm$ are obtained. The torque required to maintain the maximum speed is obtained from Eq. (1) when acceleration and road grade resistances are ignored and amounts to $3062.3Nm$. The maximum sprocket speed is calculated as $670rpm$. In accordance with this data, two electric motors of a maximum speed of $9000rpm$, a maximum torque of

600Nm and a rated power of 120kW were considered in this study. After

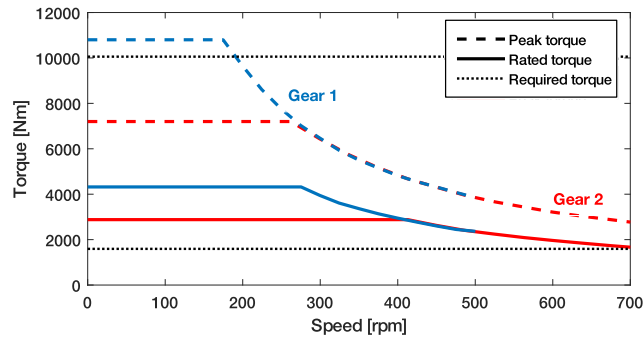

Figure 2 – Combined torque-speed curve of the traction motor and the transmission

Рис. 2 – Общая характеристика электродвигателя и трансмиссии
Слика 2 – Заједничка карактеристика електромотора и трансмисије

adopting gear ratios of $i_1 = 12$ and $i_2 = 18$, it is confirmed that the combined torque-speed characteristic of the motor and transmission satisfies the required performances as shown in Fig. 2.

Engine-generator set

In (Randive et al., 2019) engine sizing is based on the condition of meeting the required power for constant speed operation. However, in this work, an identical engine as in the reference vehicle will be adopted for the reason of achieving the validity of the comparison with the existing parallel hybrid configuration. Therefore, an engine with the power rating of 235kW is adopted.

Energy storage sizing

Considering the size of the engine-generator set in this case, the energy storage has the role of meeting required vehicle performance in the electric only mode. The power of the storage is calculated as (Arıkan, 2019):

$$P_{es} = \frac{P_{max}}{\eta}, \quad (12)$$

where P_{max} is the maximum power needed in the silent watch mode and η is the efficiency of transmission and electric motors.

The battery energy required to satisfy the performance of the silent watch mode is calculated as (Borthakur & Subramanian, 2016):

$$E_{es} = P_{ele} \cdot \frac{S}{V_{ele}}, \quad (13)$$

where S is the required silent watch autonomy, V_{ele} is the vehicle speed during silent watch (35 km/h) and P_{ele} is the power needed to drive the vehicle in a pure electric mode defined as

$$P_{ele} = \frac{1}{\eta} (m_v g f + \frac{1}{2} C_d \rho A V^2) \cdot V, \quad (14)$$

Using Eq. (12) and Eq. (13) with the desired performance parameters from Table 1, a battery with the power rating of 105kW and the energy rating of 75kWh is selected for this work. The summary of component sizes is given in Table 2.

Table 2 – Overview of the powertrain specifications
 Таблица 2 – Обзор характеристик гибридного привода
 Табела 2 – Преглед параметара хибридног погона возила

Item	Specification
Transmission	Dual-stage with ratios: $i_1 = 12, i_2 = 18$
Traction motor	Max.power: 120kW, Max.speed: 9000rpm, Max.Torque: 600Nm
Engine-generator set	Max.power: 235kW@2500rpm
Energy storage	Max.power: 105kW, Energy capacity: 75kWh

Energy management

The most common rule-based strategy in hybrid vehicles is the Thermostat Control Strategy (TCS). Other frequently represented strategies are the Power Follower Control Strategy (PFCS) and the Maximum SOC of Peak Power Supply (Max.SOC-of-PPS) (Ehsani et al., 2018). However, some more advanced rule-based strategies such as the Optimal Primary Source Strategy (OPSS) (Shabbir & Evangelou, 2019) have appeared in recent times. These strategies have a simple implementation, are robust and achieve good results, which makes them adequate candidates for



implementation in military tracked vehicles.

1. Thermostat Control Strategy is based on on/off switching of the PS depending on the battery state of charge (SOC) value. The battery SOC can vary in a predefined range $[SOC_L, SOC_U]$. Then, when the SOC reaches the lower limit, the PS turns on and recharges the battery up to the SOC_U value, when it turns off again. The PS is typically set at the most efficient operating point P_{PSopt} . The mathematical implementation is based on the state $S(t)$ which determines if the PS is active:

$$S(t) = \begin{cases} 0, & SOC(t) \geq SOC_U \\ 1, & SOC(t) \leq SOC_L \\ S(t^-) & SOC_L < SOC(t) < SOC_U \end{cases} \quad (15)$$

where SOC_L and SOC_U are the lower and upper limits of the battery SOC, and the $S(t^-)$ is the state S in the previous time sample. The PS will also supplement power if the power demand exceeds the power rating of the SS without changing the state $S(t)$.

2. Power Follower Control Strategy employs the power-following approach which means that the PS follows the load with some deviation in order to correct the battery SOC. The PS power follows the load when the SOC is between SOC_L and SOC_U but biases the PS operation in favor of charging or discharging the battery when the SOC leaves the predefined range. Mathematical implementation is similar to the TCS:

$$S(t) = \begin{cases} 0, & SOC(t) \geq SOC_U \text{ and } P_L < P_{PSmin} \\ 1, & SOC(t) \leq SOC_L \text{ or } P_L > P_{SSmax} \\ S(t^-) & SOC(t) \geq SOC_L \text{ and } P_L < P_{SSmax} \end{cases} \quad (16)$$

where P_L is the power demand, P_{PSmin} is the tunable minimum power of the PS and P_{SSmax} is the maximum power of the SS. For $S(t) = 0$ the PS power is always $P_{PS} = 0$, while for $S(t) = 1$ the PS

operation is defined as:

$$P_{PS}(t) = \begin{cases} P_{PSmin}, & SOC(t) \geq SOC_U \\ P_m(t), & SOC_L < SOC(t) < SOC_U \\ P_{PSmax} & SOC(t) \leq SOC_L \end{cases} \quad (17)$$

where P_{PSmax} is the maximum power of the PS and $P_m(t)$ is given as:

$$P_m(t) = P_L + P_{ch} \left(\frac{SOC_U + SOC_L}{2} - SOC(t) \right), \quad (18)$$

where P_{ch} is the charging factor.

3. Optimal Primary Source strategy employs the load-leveling approach using a threshold changing mechanism instead of state changing as in the TCS or the PFCS. In that way, a charge sustaining mechanism is obtained. The strategy design is strongly based on solutions gained via optimization strategies and by utilizing effectiveness of modern start-stop engine systems in HEVs (Shabbir, 2015). The threshold value for the activation of the PS is defined as

$$P_{PSmin}(SOC) = P_{th} + P_{th} \left(\frac{SOC - SOC_{initial}}{SOC_{range}} \right), \quad (19)$$

where P_{th} is the threshold value that needs to be tuned to achieve the best results. Applied to a small passenger vehicle, this strategy managed to achieve fuel consumption only 1% lower than the optimization based Equivalent Consumption Minimization Strategy (ECMS) (Shabbir & Evangelou, 2019).

Results analysis

Based on the mathematical model, a backward-looking model of the series HETV was created in the Simulink environment. For the evaluation of the model and EMS, a drive cycle was artificially constructed using the data available. The drive cycle contains the speed profiles for both tracks moving on the hard ground (Fig. 3).

It includes significant acceleration, braking, and steering. The average vehicle speed is $18.5km/h$, and the travel distance is $11.12km$. Since the drive cycle is assumed to be known, gear shifting is also predetermined such that the vehicle meets the required performance. Three proposed

EMSs were evaluated with the same initial data on the same driving cycle. The power profiles are shown in Fig. 4, and the SOC change over time is presented in Fig. 5.

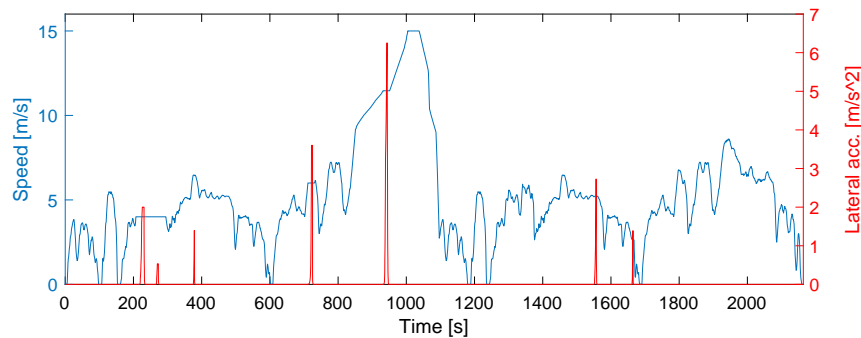

Figure 3 – Created drive cycle for the EMS evaluation

Рис. 3 – Разработанный ездовой цикл для оценки стратегии управления энергопотреблением

Слика 3 – Креирани циклус вожње за евалуацију стратегије управљања енергијом

The power profiles of the PFCS and the TCS are very similar (Fig. 4). Although the PFCS should follow the load, in this case it does not happen due to the specific vehicle exploitation conditions causing the elements of the powertrain to be oversized in order to achieve the required performance. Therefore, it seems that the PFCS is not a good choice for use in HETVs. Instead, the TCS would be a more adequate choice for HETVs due to its simplicity. On the other hand, the power profile of the OPSS is significantly different from those of the PFCS and the TCS. The load-leveling approach is noticeable and the PS always works at the optimal operating point. Also, the SOC varies significantly less than in the PFCS and the TCS, thus extending the battery life. Despite the significantly less SOC variation, with the OPSS, the engine is active about 6% time less compared to the other two strategies (Table 3). This fact directly reflects in fuel consumption, which is lower than in the other two strategies (Table 4).

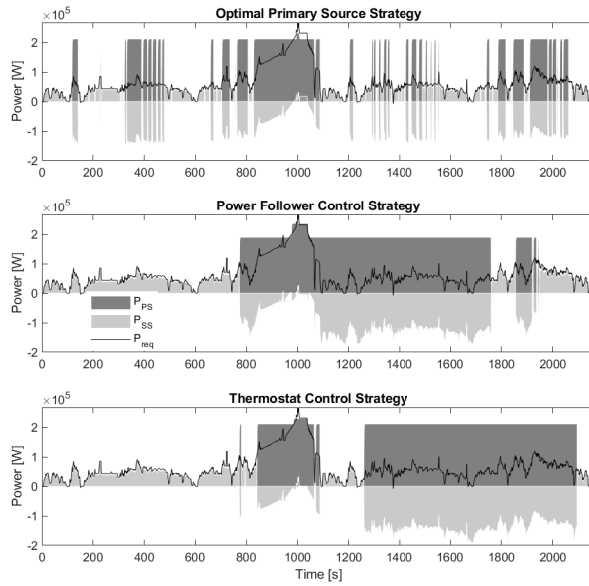

Figure 4 – Power time histories of the tested EMS

Рис. 4 – Профиль изменения мощности протестированных стратегий управления энергопотреблением

Слика 4 – Профил промене снаге код тестираних стратегија управљања енергијом

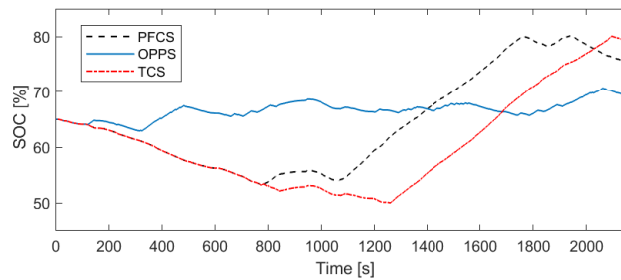

Figure 5 – Charge profiles for the TCS, the PFCS, and the OPSS

Рис. 5 – Диаграмма изменения значений SOC относительно стратегий TCS, PFCS и OPSS

Слика 5 – Дијаграм промене вредности SOC за стратегије TCS, PFCS и OPSS

The OPSS proved to be the best of the tested strategies. In addition to the best fuel economy, the small SOC variation reduces battery voltage fluctuation and increases the battery life. A constantly high battery SOC ensures the availability of electric power for auxiliary loads on or off the vehicle. In comparison with the reference vehicle from (Milićević et al., 2021), the proposed configuration with the OPSS achieves a significantly better economy of as much as 53% (Table 5).

Table 3 – Engine usage time as the percentage of the total drive cycle time

Таблица 3 – Время использования двигателя СУС, выраженное в процентах от общего времени ездового цикла

Табела 3 – Време активiranости мотора СУС изражено као проценат укупног времена трајања циклуса вожње

EMS	Engine ON time as % of total drive cycle time
TCS	50.5%
PFCS	50.51%
OPSS	44.09%

Table 4 – Fuel consumption comparison for the tested EMSs

Таблица 4 – Сопоставление расхода топлива протестированных стратегий управления энергопотреблением

Табела 4 – Поређење потрошње горива тестираних стратегија управљања енергијом

EMS	Relative fuel consumption [-]	Improvement [%]
TCS	100	-
PFCS	97.86	2.14%
OPSS	92.02	7.98%

This result is a consequence of much better powertrain sizing and a simple and adequate EMS. The initial hypothesis for the reference vehicle to change the transmission as little as possible, and then to optimize the operation of such a transmission, proved to be very unsuccessful, which showed that when hybridizing a vehicle, one must take into account the proper sizing of the powertrain elements.

The reference vehicle ended up with a slightly oversized engine and undersized electric motors and battery, which caused the engine to be active during most of the drive cycle. By switching to the series configuration and with proper sizing, significantly better results were achieved. The main reason for this is a much larger battery and more efficient operation of the engine due to the absence of a mechanical connection between the engine

and the wheels. In this work, the engine was left unchanged for the purpose of comparison with the reference vehicle; however, as Fig. 4 shows, it is clear that excess energy is created and that the engine should be downsized, which would also achieve additional fuel savings.

Table 5 – Comparison between the reference and proposed powertrain configuration and the EMS

Таблица 5 – Сопоставление серийного и предлагаемого гибридного привода и стратегии управления энергопотреблением
Табела 5 – Поређење референтног и предложеног хибридног погона и стратегије управљања енергијом

	Engine ON time	Relative fuel consumption [-]	Improvement [%]
Reference	92%	100	-
Proposed	44.09%	46.21	53.79%

Conclusion

This paper presents a systematic approach to the development of a series configuration hybrid electric tracked vehicle. All powertrain elements were systematically sized based on the key performance requirements except the engine, which remained of the same size as in the reference vehicle with the parallel hybrid configuration. Three energy management strategies were proposed, namely the TCS, the PFCS, and the OPSS. The evaluation of the powertrain configuration and the proposed strategies was performed in the Simulink environment using a driving cycle containing significant acceleration, braking and steering. The results showed that the OPSS proved to be the best due to the best fuel economy and a low battery SOC variation. The load-leveling approach enabled this strategy to have an engine usage time of 6.4% less than the other two EMSs relative to the total drive cycle time. In comparison with the same vehicle with the parallel configuration where the sizing was constrained in the sense of harnessing hybrid drive advantages with as little change of the powertrain as possible, the proposed powertrain configuration achieved a significantly better fuel economy of 53.79%. The main reasons for improved fuel economy are proper sizing, a much simpler powertrain and therefore a much more efficient EMS which enabled the engine to be active only 44.09 % of the total drive cycle time compared to 92% of the time of the parallel configuration. The main conclusion of this work is that proper sizing of powertrain elements must be taken into account when hybridizing a vehicle. Potential

fuel savings and increased efficiency outweigh the cost of radical powertrain changes. Also, the series hybrid configuration presented itself as a major candidate for use in hybrid electric tracked vehicles.

References

Arıkan, F.R. 2019. *Sizing of a series hybrid electric vehicle*. Master's thesis, Ankara, Turkey: Middle East Technical University, School of Natural and Applied Sciences [online]. Available at: <http://etd.lib.metu.edu.tr/upload/12624677/index.pdf> [Accessed: 1 September 2022].

Borthakur, S. & Subramanian, S.C. 2016. Parameter matching and optimization of a series hybrid electric vehicle powertrain system. In: *ASME International Mechanical Engineering Congress and Exposition*, vol. 50664. American Society of Mechanical Engineers, p. V012T16A003. Available at: <http://doi.org/10.1115/IMECE2016-66312>.

Ehsani, M., Gao, Y., Longo, S. & Ebrahimi, K.M. 2018. *Modern electric, hybrid electric, and fuel cell vehicles*. CRC press. Available at: <https://doi.org/10.1201/9780429504884>.

Galvagno, E., Rondinelli, E. & Velardocchia, M. 2012. Electro-mechanical transmission modelling for series-hybrid tracked tanks. *International Journal of Heavy Vehicle Systems*, 19(3), pp. 256–280. Available at: <http://doi.org/10.1504/IJHVS.2012.047916>.

Hannan, M.A., Azidin, F. & Mohamed, A. 2014. Hybrid electric vehicles and their challenges: A review. *Renewable and Sustainable Energy Reviews*, 29, pp. 135–150. Available at: <https://doi.org/10.1016/j.rser.2013.08.097>.

Jimenez-Espadafor, F.J., Marín, J.J.R., Villanueva, J.A.B., García, M.T., Trujillo, E.C. & Ojeda, F.J.F. 2011. Infantry mobility hybrid electric vehicle performance analysis and design. *Applied energy*, 88(8), pp. 2641–2652. Available at: <https://doi.org/10.1016/j.apenergy.2011.02.010>.

Khalil, G. 2009. Challenges of hybrid electric vehicles for military applications. In: *2009 IEEE Vehicle Power and Propulsion Conference*. Dearborn, MI, USA, pp. 1–3, September 7–10. Available at: <https://doi.org/10.1109/VPPC.2009.5289878>.

Liu, T., Zou, Y., Liu, D. & Sun, F. 2015. Reinforcement learning of adaptive energy management with transition probability for a hybrid electric tracked vehicle. *IEEE Transactions on Industrial Electronics*, 62(12), pp. 7837–7846. Available at: <https://doi.org/10.1109/TIE.2015.2475419>.

Milićević, S.V., Blagojević, I.A. & Muždeka, S.R. 2021. Advanced rule-based energy management for better fuel economy of hybrid electric tracked vehicle. *FME Transactions*, 49(3), pp. 711–718. Available at: <https://doi.org/10.5937/fme2103711M>.

Milićević, S. & Muždeka, S. 2021. Modelling and performance analysis of the BVP M-80A hybrid drive. *Vojnotehnički glasnik/Military Technical Courier*, 69(1), pp. 64–87. Available at: <https://doi.org/10.5937/vojtehg69-28232>.

Qin, Z., Luo, Y., Zhuang, W., Pan, Z., Li, K. & Peng, H. 2018. Simultaneous optimization of topology, control and size for multi-mode hybrid tracked vehicles. *Applied energy*, 212, pp. 1627–1641. Available at: <https://doi.org/10.1016/j.apenergy.2017.12.081>.

Randive, V., Subramanian, S.C. & Thondiyath, A. 2019. Component Sizing of Single and Dual Drive Series Hybrid Electric Powertrain for Military Tracked Vehicles. In: *2019 IEEE Vehicle Power and Propulsion Conference (VPPC)*. Hanoi, Vietnam, pp. 1–6, October 14–17. Available at: <https://doi.org/10.1109/VPPC46532.2019.8952308>.

Randive, V., Subramanian, S.C. & Thondiyath, A. 2021. Design and analysis of a hybrid electric powertrain for military tracked vehicles. *Energy*, 229, p. 120768. Available at: <https://doi.org/10.1016/j.energy.2021.120768>.

Rizzo, D.M. 2014. *Military vehicle optimization and control*. Ph.D. thesis, Michigan Technological University. Available at: <https://doi.org/10.37099/mtu.dc.ets/863>.

Shabbir, W. 2015. *Control Strategies for Series Hybrid Electric Vehicles*. Ph.D. thesis, Imperial College London. Available at: <https://spiral.imperial.ac.uk/bitstream/10044/1/39791/1/Shabbir-W-2015-PhD-Thesis.pdf>.

Shabbir, W. & Evangelou, S.A. 2019. Threshold-changing control strategy for series hybrid electric vehicles. *Applied energy*, 235, pp. 761–775. Available at: <https://doi.org/10.1016/j.apenergy.2018.11.003>.

Wong, J.Y. 2022. *Theory of ground vehicles*. John Wiley & Sons. Available at: <http://doi.org/10.1002/9781119719984>.

Wu, G., Zhang, X. & Dong, Z. 2013. *Impacts of two-speed gearbox on electric vehicle's fuel economy and performance*, vol. 2. Warrendale, PA, USA: SAE International. Available at: <https://doi.org/10.4271/2013-01-0349>.

Zhang, B., Guo, S., Zhang, X., Xue, Q. & Teng, L. 2020. Adaptive smoothing power following control strategy based on an optimal efficiency map for a hybrid electric tracked vehicle. *Energies*, 13(8), p. 1893. Available at: <https://doi.org/10.3390/en13081893>.

Zou, Y., Liu, T., Liu, D. & Sun, F. 2016. Reinforcement learning-based real-time energy management for a hybrid tracked vehicle. *Applied energy*, 171, pp. 372–382. Available at: <https://doi.org/10.1016/j.apenergy.2016.03.082>.

Zou, Y., Sun, F., Hu, X., Guzzella, L. & Peng, H. 2012a. Combined optimal sizing and control for a hybrid tracked vehicle. *Energies*, 5(11), pp. 4697–4710. Available at: <https://doi.org/10.3390/en5114697>.

Zou, Y., Sun, F.C., Zhang, C.N. & Li, J.Q. 2012b. Optimal energy management strategy for hybrid electric tracked vehicles. *International Journal of Vehicle Design*, 58(2-4), pp. 307–324. Available at: <https://doi.org/10.1504/IJVD.2012.047390>.

МОЩНОСТЬ И УПРАВЛЕНИЕ ЭНЕРГОПОТРЕБЛЕНИЕМ ГИБРИДНОЙ ГУСЕНИЧНОЙ МАШИНЫ ОБЫЧНОЙ КОНФИГУРАЦИИ

Стефан В. Миличевич, **корреспондент**, Иван А. Благоевич

Белградский университет, машиностроительный факультет,
кафедра моторных автомобильных транспортных средств, г.
Белград, Республика Сербия

РУБРИКА ГРНТИ: 78.25.09 Военная автомобильная техника,
78.25.10 Бронетанковая техника

ВИД СТАТЬИ: оригинальная научная статья

Резюме:

Введение/цель: В данной статье представлен системный подход к разработке серийного гибридного электрического гусеничного транспортного средства (ГЭТС), включая выбор привода и соответствующей стратегии управления энергопотреблением (ЭМС).

Методы: Размеры элементов силового агрегата были подобраны с учетом ключевых требований к производительности. Были предложены три стратегии управления энергопотреблением: стратегия управления с помощью термостата (TCS), стратегия управления повторителем мощности (PFC) и стратегия оптимального источника питания (OPSS). Оценка конфигурации трансмиссии и трех предложенных стратегий была выполнена в среде Simulink с использованием ездового цикла, включающего значительное ускорение, торможение и рулевое управление.

Результаты: Результаты показали, что OPSS оказалась лучшей стратегией, благодаря экономии топлива и низкому уровню изменчивости заряда батареи (SOC). Надо подчеркнуть, что по сравнению с предыдущими испытаниями того же автомобиля с параллельной гибридной конфигурацией были достигнуты значительно лучшие результаты. Анализ результатов показывает, что предложенная кон-

фигурација привода и стратегија управљена обезбеђују снижење расхода горива на 53,79 %, што сведочи о правилном избору величине хибридног привода.

Выводи: Резултати овог истраживања представљају велику значајност за разумевање утицаја правилног избора величине привода на економичност транспортног средства. У поређењу са серијним транспортним средством, предложена конфигурација обезбеђује значајно побољшање, нарочито, захваљујући одговарајућем избору величине. Према издвојеној хипотези, најбољом стратегијом показала се OPSS. Серијна хибридна конфигурација са OPSS као ЕМС показала се најбољом кандидатом за коришћење ГЕТС.

Кључне речи: гусенична машина, хибридна машина, енергопотрошња, стратегија управљена енергопотрошњом, расход горива.

ДИМЕНЗИОНИСАЊЕ ПОГОНА И УПРАВЉАЊЕ ЕНЕРГИЈОМ ХИБРИДНОГ ГУСЕНИЧНОГ ВОЗИЛА РЕДНЕ КОНФИГУРАЦИЈЕ

Стефан В. Милићевић, аутор за преписку, Иван А. Благојевић

Универзитет у Београду, Машински факултет, Катедра за моторна возила, Београд, Република Србија,

ОБЛАСТ: машинство

КАТЕГОРИЈА (ТИП) ЧЛАНКА: оригинални научни рад

Сажетак:

Увод/циљ: У раду је представљен систематски приступ развоју редног хибридног електричног гусеничног возила (ХЕТВ) укључујући димензионисање погона и избор одговарајуће стратегије управљања енергијом (ЕМС).

Метод: Елементи погонског склопа су димензионисани, узимајући у обзир кључне захтеве перформанси. Предложене су три стратегије управљања енергијом: термостатска стратегија (ТЦС), стратегија управљања праћењем оптерећења (ПФЦС) и стратегија оптималног извора енергије (ОПСС). Евалуација конфигурације погона и три предложене ЕМС извршене су у окружењу Симулинк ко-



ришћењем циклуса вожње који садржи делове са знатним убрзањима, кочењима и управљањем.

Резултати: Резултати су показали да се ОПСС показала као најбоља стратегија због повећане уштеде горива и ниске варијације стања напуњености батерије (СОЦ). У поређењу са претходним истраживањем истог возила са паралелном хибридном конфигурацијом, постигнути су знатно бољи резултати. Анализа резултата показује да се предложеном конфигурацијом погона и стратегијом управљања потрошња горива смањује за 53,79 %, што указује на то да је димензионисање хибридног погона правилно изведено.

Закључак: Резултати овог рада су од великог значаја за разумевање утицаја правилног димензионисања погона на економичност возила. У поређењу са референтним возилом, предложена конфигурација постиже значајно побољшање, од којег се највећи део приписује адекватном димензионисању. ОПСС се показала као најбоља стратегија, чиме је потврђена теоријска хипотеза. Показало се да је редна хибридна конфигурација са ОПСС као ЕМС најбоља за употребу у ХЕТВ-у.

Кључне речи: гусенично возило, хибридно возило, управљање енергијом, стратегија управљања енергијом, потрошња горива.

Paper received on / Дата получения работы / Датум пријема чланка: 03.09.2022.
Manuscript corrections submitted on / Дата получения исправленной версии работы / Датум достављања исправки рукописа: 14.10.2022.

Paper accepted for publishing on / Дата окончательного согласования работы / Датум коначног прихватања чланка за објављивање: 15.10.2022.

© 2022 The Authors. Published by Vojnotehnički glasnik / Military Technical Courier (<http://vtg.mod.gov.rs>, <http://vtr.mo.ynp.cb>). This article is an open access article distributed under the terms and conditions of the Creative Commons Attribution license (<http://creativecommons.org/licenses/by/3.0/rs/>).

© 2022 Авторы. Опубликовано в "Военно-технический вестник / Vojnotehnički glasnik / Military Technical Courier" (<http://vtg.mod.gov.rs>, <http://vtr.mo.ynp.cb>). Данная статья в открытом доступе и распространяется в соответствии с лицензией "Creative Commons" (<http://creativecommons.org/licenses/by/3.0/rs/>).

© 2022 Аутори. Објавио Војнотехнички гласник / Vojnotehnički glasnik / Military Technical Courier (<http://vtg.mod.gov.rs>, <http://vtr.mo.ynp.cb>). Ово је чланак отвореног приступа и дистрибуира се у складу са Creative Commons лиценцом (<http://creativecommons.org/licenses/by/3.0/rs/>).

